

# Vapac



## ELECTRIC UNIT HEATER



### INSTALLATION, COMMISSIONING AND SERVICING MANUAL



These appliances meet the following directives:  
The Eco design for Energy-Related Products and Energy Information (Amendment) (EU Exit)  
Regulations 2020  
Electromagnetic Compatibility Regulations 2016  
Electrical Equipment (Safety) Regulations 2016  
Supply of Machinery (Safety) Regulations 2008  
Supply of Machinery (Safety) Regulations (A) 2011

Please read this document carefully before commencing installation, commissioning and/or servicing.  
Leave it with the end user/site agent to be placed in their premises technical file after installation.

#### WARNING

Improper installation, adjustment, alteration, service or maintenance can cause property damage, injury or death.  
All work must be carried out by appropriately qualified persons.

The manufacturer does not take any responsibility in the event of non-observance of the regulations concerning the connection of the apparatus causing a dangerous operation possibly resulting in damage to the apparatus and/or environment in which the unit is installed.



# Contents

---

## General Information (G)

---

e+ range .....	4
Using this manual .....	4
Warranty .....	4
Important notice to installers .....	5
Health and safety .....	6

## Technical Data (TD)

---

Technical data .....	8
Dimensions .....	12
Clearance distances .....	13
Signal pro display panel dimensions .....	14

## Installation (I)

---

Heater location .....	16
Uncrating / preparation .....	16
Accessory kit .....	17
Hanging the heater .....	17
Electrical supply .....	19
Thermostat controls .....	20
Signal Pro display panel .....	20
Wiring diagram .....	21
Protection .....	21

## Controller, Operation and Commissioning (C)

---

Introduction .....	22
Networking .....	22
Heater addressing .....	23
Keypad buttons .....	23
Set language .....	23
User menu .....	23
Engineers menu .....	23
Diagnostic display .....	24
Normal operation .....	24

Features .....	24
Configuration program key .....	25
Fan speeds .....	25
Temperature sensors .....	25
Thermal cut-out .....	26
Timer / BMS input .....	26
Door / off input .....	26
Network data format and data protocol .....	26
Commissioning - start up .....	26
Commissioning - handover .....	27
Operation .....	27
Overheat protection .....	27

## Maintenance and Servicing (MS)

---

General Maintenance .....	28
Removal of grille .....	28
Removal of heating element .....	28
Replacement of LC3 limit thermostat .....	29
Replacement of thermistor bead .....	29
Locating the sensor bracket and sensors .....	30
Replacement of fan .....	30
Replacement of controller .....	30

## Fault Finding (FF)

---

General .....	31
Display panel .....	31
Fault finding chart .....	32

## Spare Parts (SP)

---

Spare parts .....	34
Exploded view .....	35

## ErP Data (ErP)

---

e+ 10 .....	36
e+ 20 .....	37
e+ 30 .....	38

## General product information

The e+ range is the latest generation of electric unit heaters, UKCA certified to BS EN 60335-1 and -2-30 for use in non domestic installations.

There are three models in the range with heating duties of 10, 20 and 30kW respectively. All models have been designed for a three phase electrical supply. Details of the unit duty and electrical supply requirement are given on the heater rating plate. Check the rating plate to determine if the heater is appropriate for the intended installation.

This installation manual is shipped with the unit. Verify that the literature is correct for the model being installed. If the manual is incorrect for the heater, contact the supplier before beginning installation.

The instructions in this manual apply only to the models listed.

Installation should be carried out by a suitably qualified installer in accordance with these instructions and the current rules and regulations in force. The installer is responsible for the safe installation of the heater.

## Using this manual

The symbols for 'Caution' and 'Warning' are used to highlight certain points throughout this manual.



**Caution is used when failure to follow or implement the instruction(s) can lead to premature failure or damage to the heater or its component parts.**



**Warning is used when failure to heed or implement the instruction(s) can lead to not only component damage, but also to a hazardous situation being created where there is a risk of personal injury.**

## Warranty

This equipment comes as standard with a manufacturers two year warranty (2 years parts, 1 year labour) unless agreed otherwise at the time of order. The warranty is void if:

1. The installation is not in accordance with these instructions.
2. Wiring is not in accordance with the diagram furnished with the heater.
3. The unit is installed without proper clearances wherever clearances are required regardless of the material being combustible.
4. The unit is installed without proper ventilation.
5. The equipment is used in atmospheres containing flammable vapours or chlorinated or halogenated hydrocarbons or any contaminant (silicon, aluminium oxide, etc.).
6. The unit has not been serviced and maintained in accordance with the information contained within these instructions.
7. An appliance is connected to a duct system or the air delivery system is modified in any way.



**Ignoring the warning and caution notices and the advice from the manufacturer on installation, commissioning, servicing or use, will jeopardise any applicable warranty. This could also compromise the safe and efficient running of the appliance itself and thereby constitute a hazard.**

**The electrical isolator should only be used for maintenance purposes or in an emergency.**

## Important notice to installers

---

Before installation, carefully read these instructions and follow the processes explained by the manufacturer. These instructions are only valid for appliances designed to operate in Europe. If the country code on the appliance data label does not match the country of installation or the country codes as shown in this instruction manual, it will be necessary to contact the distributor or manufacturer to provide the necessary information for the modification of the appliance to the conditions of use for the country of installation.

Installing, commissioning, testing, programming and maintenance of these products must only be carried out by suitably qualified and trained technicians and in full compliance with all applicable regulations and current best practices.

Check if the appliance as described on the packaging label is in accordance with the correct type and model as specified on the data plate and complies with your customer order.

Check that the temperature ranges given and those of the location match. The appliance must be powered with a voltage corresponding to the value shown on the rating plate.

These units must be installed in accordance with the rules in force and local regulations / legislation as appropriate plus all local building codes. Installers should satisfy themselves that the electrical installation is carried out in accordance with all current legislation, Codes of Practice and recommendations.



**Improper installation, adjustment, alteration, service, or maintenance can cause property damage, injury, or death. Read the installation, operation, and maintenance instructions thoroughly before installing or servicing this equipment.**

G

These appliances are not designed for use in hazardous atmospheres containing flammable vapours or combustible dust, in atmospheres containing chlorinated or halogenated hydrocarbons or in applications with airborne silicone substances.

These appliances are not designed for use at altitudes above 2000m.

Any reference made to Laws, Standards, Directives, Codes of Practice or other recommendations governing the application and installation of heating appliances and which may be referred to in Brochures, Specifications, Quotations, and Installation, Operation and Maintenance manuals is done so for information and guidance purposes only and should only be considered valid at the time of the publication.

The manufacturer cannot be held responsible from any matters arising from the revision to or introduction of new Laws, Standards, Directives, Codes of Practice or other recommendations.

**G**

## Health and safety

---

Ensure that anchoring points are suitable for the weight and loading of the product and if required, add suitable reinforcement to the anchoring points area.

Due consideration should be taken for workplace safety, risk assessments and waste disposal.

Any modification of the product may be hazardous and the manufacturer is not liable for any damage or injury caused by improper use.

Do not use this appliance if any part has been immersed in water. Immediately call a qualified service technician to inspect the appliance and replace any control that has been immersed in water.

This appliance can be used by persons (including children over 8) with reduced sensory or mental capabilities or lack of experience and knowledge, if they have been given supervision or instruction concerning use of the appliance in a safe way and understand the hazards involved. Cleaning and user maintenance should not be carried out by children without supervision. Children should be supervised to ensure that they do not play with the appliance.

This manual should be kept in a safe place for future reference.



**Do not use the heater in areas where there is an explosion risk or where there are inflammable gases such as ammonia, paint thinners or glue.**

**Do not use the heater in an environment with airborne contaminants such as dust as it may accumulate within the heater and could create a fire risk or other defect of the heater.**

**Do not store or use petrol or other flammable vapours and liquids in the vicinity of the appliance. Do not place inflammable objects in front of the heater outlet.**

**Do not cover the heater. Ensure the air inlet and outlet are not obstructed.**

**Do not install the heater near or below a socket outlet.**

**Improper installation, adjustment, alteration, service or maintenance can cause property damage, injury or death.**

**Read the installation, operation and maintenance instructions thoroughly before installing or servicing this equipment.**

**Installation, assembly, commissioning, service and maintenance procedures must be carried out only by suitably competent qualified persons.**

**Unauthorised modifications to the appliance, or departure from the manufacturer's guidance on intended use, or installation contrary to the manufacturer's recommendations may constitute a hazard.**

**Frequent maintenance and cleaning of the air heater is necessary to ensure safe and proper operation. Failure to do so could lead to damage to the heater or its surroundings and void the warranty**

**Use only factory authorised parts and spares when replacement is required.**

**In case of persistent problems, contact your distributor.**

This page is intentionally blank

# Technical Data

TD

Item	Unit	@ 415V	@400V	@380V
<b>Model e+ 10 - Airflow Speed F1</b>				
Maximum Heating Capacity	kW	10.76	10.00	9.03
Maximum Heating Load per Phase	A	14.98	14.43	13.71
Airflow	m <sup>3</sup> /h	1275		
Throw	m/s @ m	0.5 m/s @ 19.5m		
Noise @ 5m	dB(A)	53.0		
NR Rating	NR	50		
Maximum Fan Power	W	332		
Fan Running Current	A	0.4		
Maximum Temperature Rise ΔT	°C	25	23	21
Outlet Temperature Setting H1	°C	30		
Outlet Temperature Setting H2	°C	34		
Outlet Temperature Setting H3	°C	38		
<b>Model e+ 10 - Airflow Speed F2</b>				
Maximum Heating Capacity	kW	10.76	10.00	9.03
Maximum Heating Load per Phase	A	14.98	14.43	13.71
Airflow	m <sup>3</sup> /h	1500		
Throw	m/s @ m	0.5 m/s @ 21.8m		
Noise @ 5m	dB(A)	58.5		
NR Rating	NR	55		
Max Fan Power	W	332		
Fan Running Current	A	0.6		
Maximum Temperature Rise ΔT	°C	21	20	18
Outlet Temperature Setting H1	°C	30		
Outlet Temperature Setting H2	°C	33		
Outlet Temperature Setting H3	°C	36		
<b>Model e+ 20 - Airflow Speed F1</b>				
Maximum Heating Capacity	kW	21.53	20.00	18.05
Maximum Heating Load per Phase	A	29.95	28.87	27.42
Airflow	m <sup>3</sup> /h	2000		
Throw	m/s @ m	0.5 m/s @ 29.7m		
Noise @ 5m	dB(A)	64.8		
NR Rating	NR	60		
Max Fan Power	W	332		
Fan Running Current	A	1.3		
Maximum Temperature Rise ΔT	°C	33	30	27
Outlet Temperature Setting H1	°C	30		
Outlet Temperature Setting H2	°C	38		
Outlet Temperature Setting H3	°C	45		

**Note:**

The heaters by default are designed and set to run at fan speed F1. Fan speed F2 is a "boost" mode; as well as giving an increase in heat output and airflow from the heater, they will give a commensurate increase in the noise level produced.





Item	Unit	@ 415V	@400V	@380V
<b>Model e+ 20 - Airflow Speed F2</b>				
Maximum Heating Capacity	kW	21.53	20.00	18.05
Maximum Heating Load per Phase	A	29.95	28.87	27.42
Airflow	m <sup>3</sup> /h	2250		
Throw	m/s @ m	0.5 m/s @ 34.1m		
Noise @ 5m	dBA	68.9		
NR Rating	NR	65		
Max Fan Power	W	332		
Fan Running Current	A	1.9		
Maximum Temperature Rise ΔT	°C	29	26	24
Outlet Temperature Setting H1	°C	30		
Outlet Temperature Setting H2	°C	35		
Outlet Temperature Setting H3	°C	40		
<b>Model e+ 30 - Airflow Speed F1</b>				
Maximum Heating Capacity	kW	32.29	30.00	27.08
Maximum Heating Load per Phase	A	44.93	43.30	41.14
Airflow	m <sup>3</sup> /h	3000		
Throw	m/s @ m	0.5 m/s @ 36.9m		
Noise @ 5m	dBA	69.9		
NR Rating	NR	66		
Max Fan Power	W	520		
Fan Running Current	A	1.5		
Maximum Temperature Rise ΔT	°C	32	30	27
Outlet Temperature Setting H1	°C	30		
Outlet Temperature Setting H2	°C	38		
Outlet Temperature Setting H3	°C	45		
<b>Model e+ 30 - Airflow Speed F2</b>				
Maximum Heating Capacity	kW	32.29	30.00	27.08
Maximum Heating Load per Phase	A	44.93	43.30	41.14
Airflow	m <sup>3</sup> /h	3250		
Throw	m/s @ m	0.5 m/s @ 39.4m		
Noise @ 5m	dBA	71.8		
NR Rating	NR	68		
Max Fan Power	W	520		
Fan Running Current	A	1.8		
Maximum Temperature Rise ΔT	°C	30	28	25
Outlet Temperature Setting H1	°C	30		
Outlet Temperature Setting H2	°C	35		
Outlet Temperature Setting H3	°C	40		
<b>All Models</b>				
Electrical Supply	V/Ph/Hz	380-415V / 3Ph+N / 50 Hz		
Protection	IP	10		

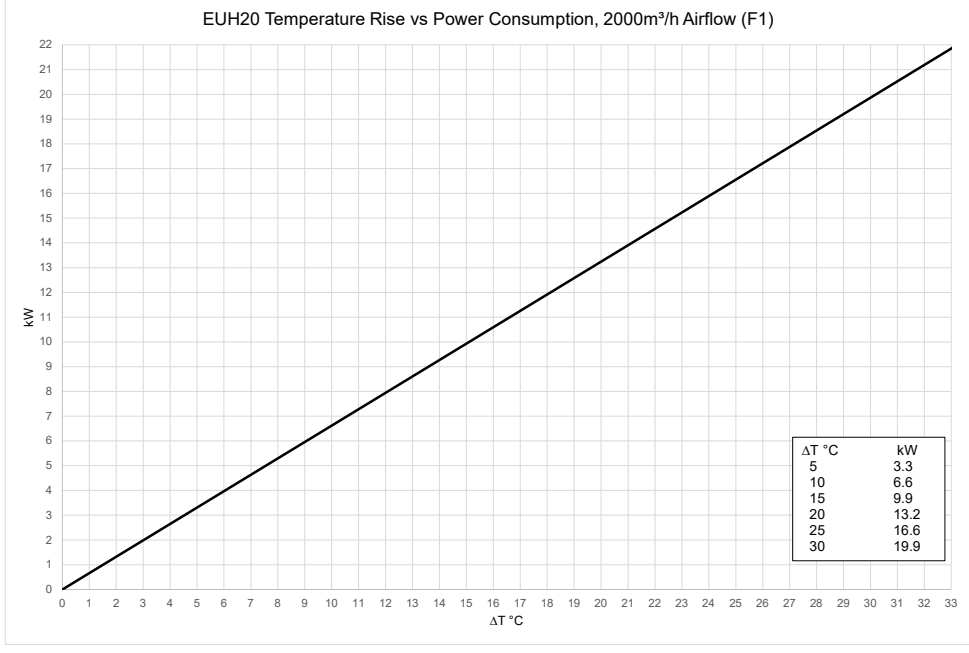
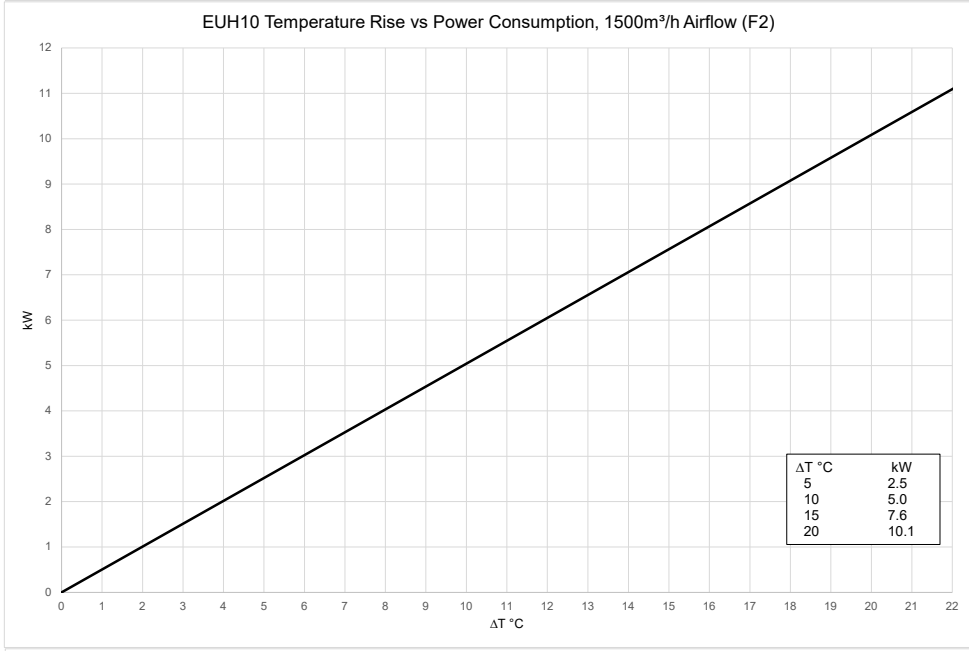
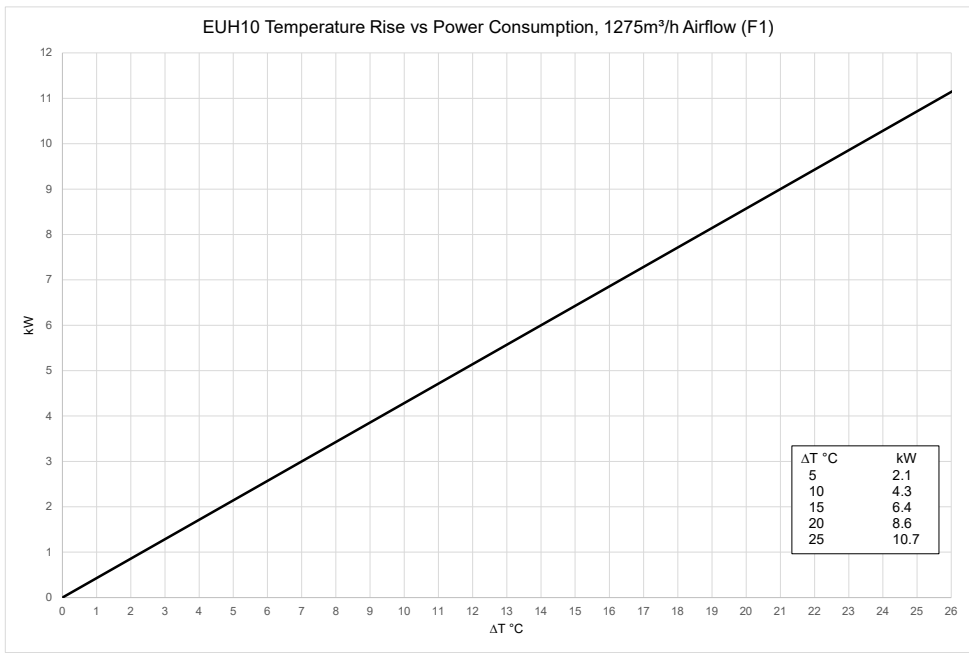

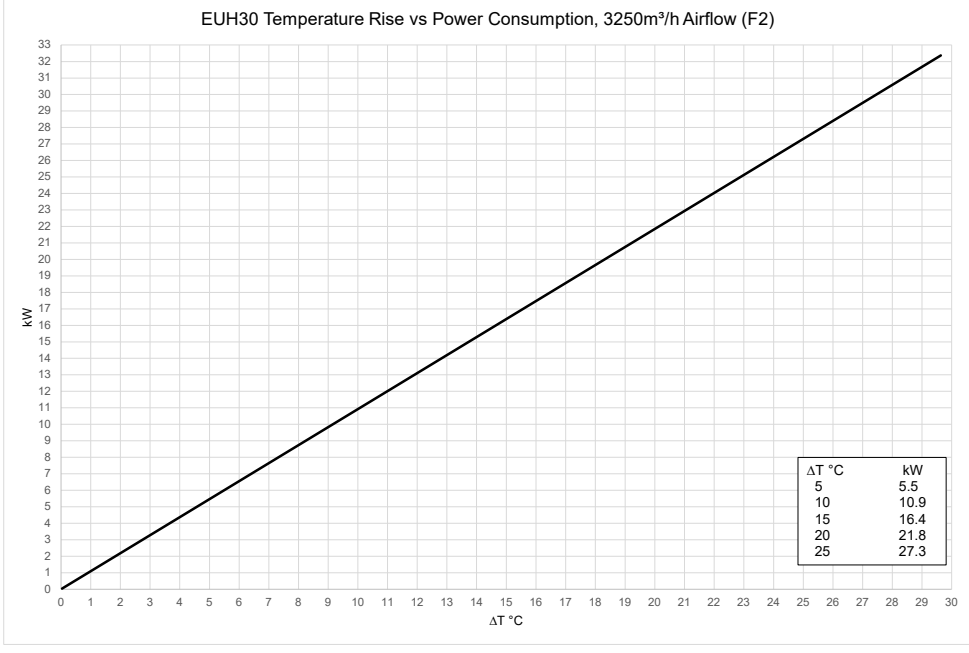
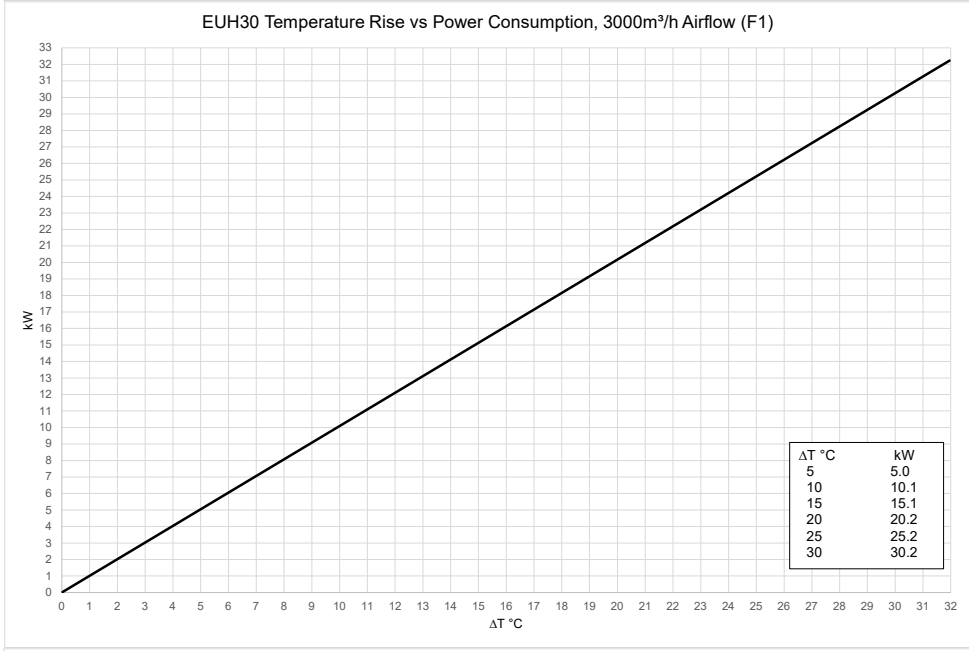
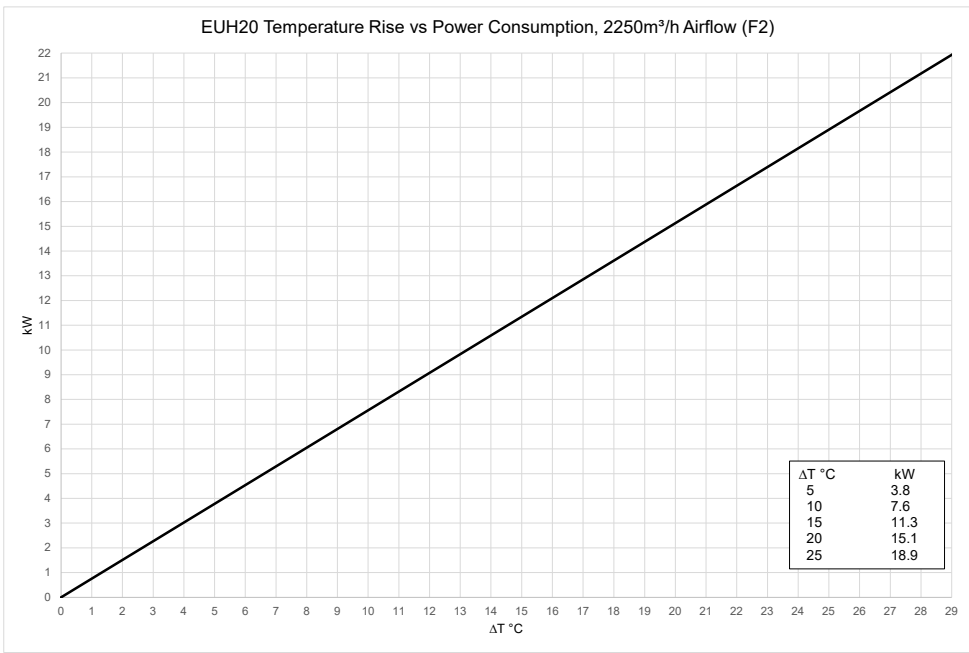

# Dimensions

TD

Model	Unit	e+ 10	e+ 20	e+ 30
Diameter	mm	526	526	526
Length	mm	530	530	680
Total width with hanging bracket	mm	590	590	590
Total height with hanging bracket	mm	735	735	735
Hanging bracket mounting holes	-	2 off 10mm diameter holes at 100mm centres		
Weight	kg	20.6	21.5	24.1

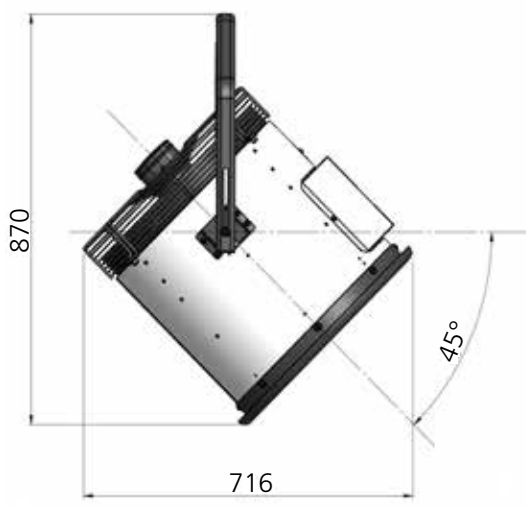
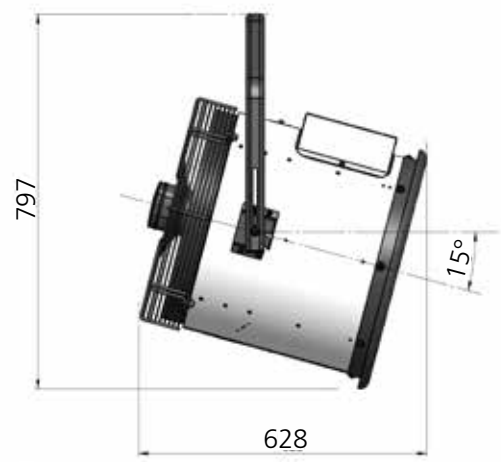
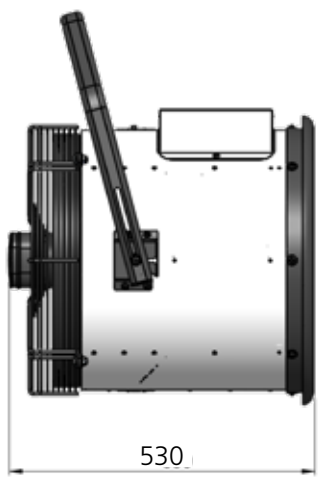
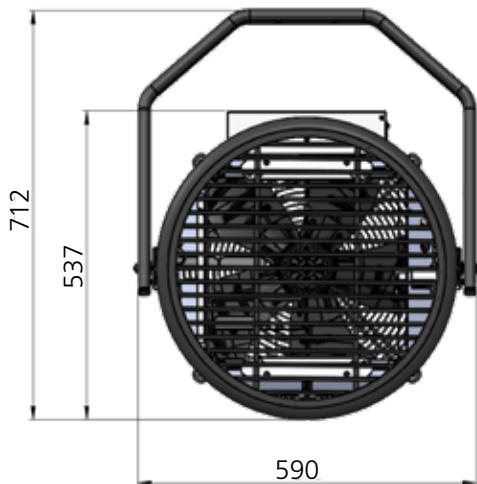

**e+ 10 and 20**

# Clearances



Model	Unit	e+ 10	e+ 20	e+ 30
Front minimum (*1) (*2)	mm	1200	1200	1200
Rear minimum	mm	450	450	450
Side minimum (*1) (*2) (*3)	mm	60	60	60
Above access Panel	mm	1000	1000	1000
Minimum Mounting Height	mm	2500	2500	2500
Maximum Mounting Height (*4)	mm	5000	7000	9000

Notes:-

- (\*1) Minimum distance to surface surrounding heater
- (\*2) At these minimum clearances, the surface could be subject to a temperature rise of up to 60°C
- (\*3) One side of the heater must be unobstructed
- (\*4) Maximum mounting height is based the heater being installed at the 45 degree mounting angle and ensures that the direct distance from heater to floor level is considerably less than the product maximum throw. This ensures that the heated airflow from the product will reach floor level.

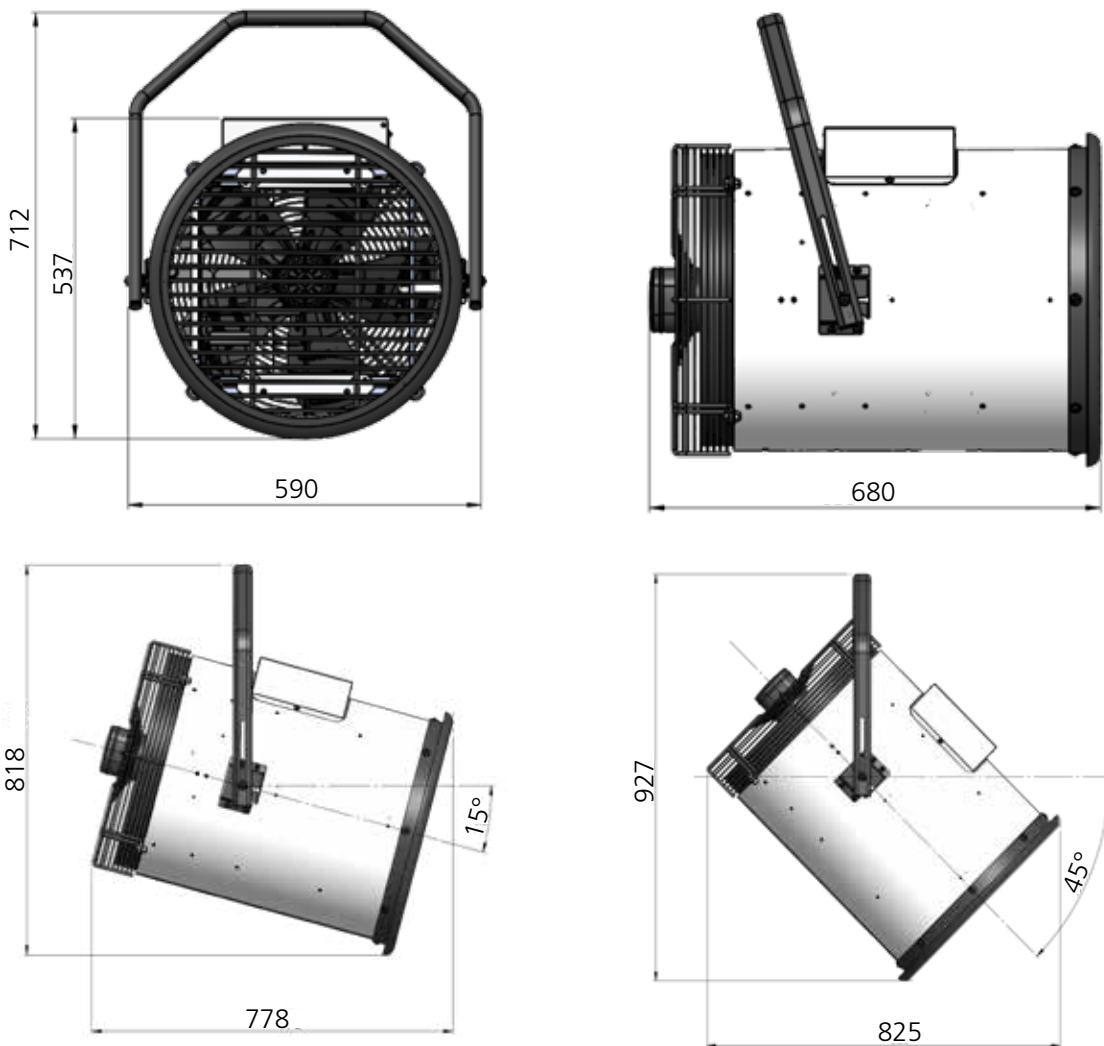

### Signal Pro display panel dimensions

The Signal Pro display panel (provided separately as part of the accessory kit) is supplied with an industry standard plastic double surface mounted socket box. Alternatively, the display panel can be flush mounted using a customer supplied metal flush conduit box.



Figure 1 display panel in surface mount box

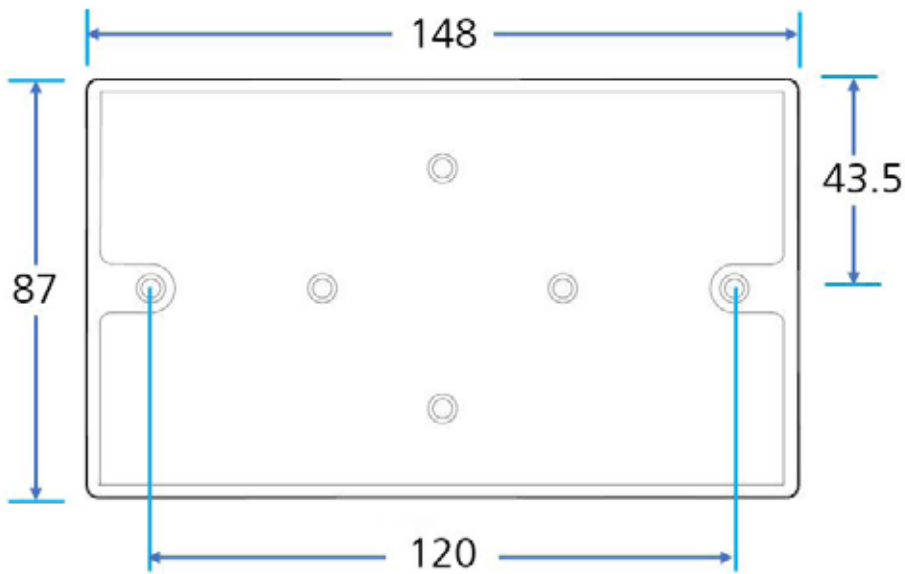

Figure 1.1 surface mount box dimensions

This page is intentionally blank

# Installation

## Heater location



**This air heater must be installed and maintained in accordance with this manual, national and local building regulations and local health and safety regulations**



**Do not use the air heater in a very dusty environment. Dust may accumulate and cause a defect of the heater. This is also the case for the room thermostat.**

For best results, the heater should be located with certain rules in mind:-

- Always ensure that the minimum clearances detailed previously are maintained.
- When possible, heaters should be arranged to blow toward or along exposed wall surfaces.
- Suspended heaters are most effective when located as close to the working zone as possible, but care should be exercised to avoid directing the discharged air directly on to room occupants.
- Partitions, columns, counters or other obstructions should be taken into consideration when locating the unit heater so that a minimum quantity of airflow will be deflected by such obstacles.
- When unit heaters are located in the centre of the space to be heated, the air should be discharged toward outside / external walls.
- In large areas, unit heaters should be located to discharge air along exposed walls with extra units provided to discharge air in toward the centre of the area. For optimum results heaters are best used in conjunction with recirculating / destratification air fans suspended at high level. Contact the manufacturer / distributor for more details.
- At those points where infiltration of cold air is excessive, such as at entrance doors and roller doors, it is desirable to locate the unit so that it will discharge directly toward the source of cold air, typically from a distance of 4.5 to 6.0 metres.

## Uncrating / preparation

Prior to crating and shipping, this unit was test operated and inspected at the factory and left in full operating condition. If the unit has incurred damage in shipment, document the damage with the transport company and contact your supplier.

The installation manual is located in a document holder on the outside of the packing. Read the manual and become familiar with the installation requirements of your unit.

Check if the local electricity supply is compatible with the data plate.

The appliance must be installed in accordance with the current rules in force and any local or national regulations.

The requirements of the "Local Building Standards office", the premises "Insurance" undertaking and the "Fire Office" must also be observed.

Before commencing installation, ensure all necessary supplies, tools and manpower are available.

To unpack and prepare the heater for installation:-

1. Open the box, snip the cable tie and remove the cardboard disk.





- Lift the hanging bracket to the vertical position, slotting it in to place.



Keep the heater in the packing until ready for installation. Alternatively, the heater can be stood on the cardboard disk provided as part of the packing.



All packing with the exception of the cable tie is recyclable.

### Accessory kit

A separate accessory kit (EUH-CTRL-KIT-10M/30M/50M) can be purchased for the heater. The kit contains the following:-

- Room thermostat (part number 29-01-219)
- Display panel
- RJ45 cable (10m, 30m or 50m long dependent on the accessory kit) to connect the display to the PCB control board at the Unit



### Hanging the heater



**Do not locate the heater where it may be exposed to water or where the ambient temperature exceeds 30°C.**

**Ensure that the structural elements, which will be used to suspend or support the appliance, are adequate to carry the weight of the appliance. Unit weights are given in the technical data section previously.**

**Sufficient space must be provided around the heater for servicing and clearances for safety.**

**Always provide a minimum clearance of 600mm at the open air intake (inlet side)**

**Suspend the heater only from the mounting bracket provided with the heater.**

**Do not add additional weight to the mounted heater.**

**The minimum safe mounting height is 2.5 metres.**

**Ensure the air flow to and from the heater is free of obstacles.**

**Ensure there is at least 5 metres clear from obstruction in front of the heater.**

**Do not mount the heater in the vertical position - this is for installation purposes only. The heater must be mounted in either the 15° or 45° position.**

To hang the heater:-

1. Install suitably sized and supported unistrut (sufficient to carry the weight of the unit) in the roof space.
2. Fix two 10mm (M10) vertical threaded rods of the required length at 100mm centres to the unistrut.
3. Holding the hanging bracket at the unit, pass the vertical threaded rod through the bracket holes and bolt off the ends once through. If required, use double locking nuts for extra security.
4. Once the unit is hanging from the supports, the electrical supply, controller cable and thermostat can be installed as described overleaf.
5. Adjust the heater to either the 15° or 45° position as required using the angling slots. DO NOT use the heater in the vertical position. Note that the heater will need to be lifted slightly to disengage it from the vertical slot and allow rotation.

6. Lock the hanging bracket in place using the M8 screws and M8 nyloc nuts (on the inside of the bracket) where the hanging bracket connects to the heater.

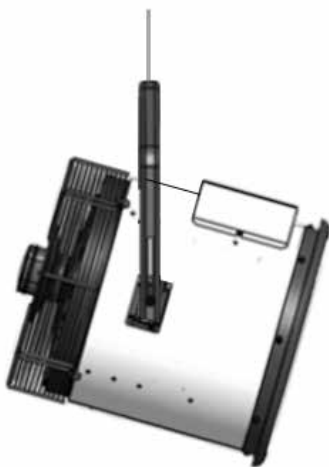

15° position



45° position

## Electrical supply.



**The electrical installation may only be carried out by an appropriately qualified person in accordance with the current Rules and Regulations in force.**

**This appliance must be earthed.**

**Due to the heater having “Fan Over Run” circuitry the heater must not be turned ON and OFF using the mains supply isolator. The mains supply isolator should only be used in an emergency or if you need to turn off the heater (once cooled down) for long periods.**

**For safety reasons, a sound earth connection must always be made to the unit before it is put in to use. The unit should be wired in accordance with Regulations for the Electrical Equipment of Buildings.**

**A qualified electrician needs to calculate the correct cable size to be used based on the maximum current the appliance can draw and considering all relevant cable correction factors.**

**The maximum conductor size that the appliance terminals can accept is 16mm<sup>2</sup>. For long cable runs that require a cable size greater than 16mm<sup>2</sup>, it is recommended to position a fused switch near to the appliance and step down the cable size.**



**The display panel is connected to the control panel (base unit) via an RJ45 cable with a maximum length of 100m. It is recommended that screened cable is used to avoid electrical interference.**

Units require a connection to a 3 phase 380-415V, neutral and earth power supply. The models consume 10kW, 20kW and 30kW respectively at 400 Volts when switched to the full heat position depending on the model and capacity setting. Check that the electrical specification is in accordance with the specified data on the air heater.

The appliance MUST be connected to the supply via a switched fused isolator, appropriately sized to suit the total electrical load and having a contact separation of greater than 3mm. See technical data for fuse rating on pages 8 and 9.

Check that the air heater is well earthed and that an earth leakage test is carried out.

All electrical connections must be made in the heater control compartment on top of the heater. The cover is hinged, held in place with one M6 Torx bolt. Once the cover has been opened, the PCB and terminal block are visible. The terminal block and PCB are used for the connection of the mains supply and additional controls, for example the external thermostat. Wiring must be carried out in accordance with the unit wiring diagram given on page 21.

It is essential that the main input line and neutral remain live at all times even when the unit is switched off to ensure correct operation of the unit and to let the fan operate independent of the heating control. Never incorporate controls that isolate the appliance electrically.

## Thermostat controls

The minimum external control required for the unit is a room thermostat (part number 29-01-219) is supplied with the accessory kit discussed earlier.

The location of the room thermostat or sensor is very important. It should not be positioned on a cold wall or cold surface. Avoid location in draughty areas or where it may be influenced by heat sources e.g. the sun, process plant, etc. The thermostat should be mounted on a vibration free surface and mounted about 1.5 metres above floor level.

## Signal Pro display panel

The display panel can be installed using the standard double surface box supplied or recessed using a suitable flush mounted double conduit box.

**I** The display panel can be connected up to a maximum of 16 unit heaters in one network. For mains wiring refer to the wiring diagram adjacent.

The display panel is connected to the base unit in the heater via a pre-wired RJ45 cable/plug. These cables are available in 2, 10, 20, 30, 50 and 100m lengths. It is recommended that this control cable is run separately within its own trunking to avoid external interference.



**Maximum cable run in any network must not exceed 100m in total including display panel cable.**

**Note:** All heaters connected within the network system will operate under the settings of the single display panel. See "Installer initial setup" on page 24 to register all heaters in the network with the display panel.

Any heater within the network can be connected with and respond to the following optional circuits:

- External switch (i.e. BMS enable) where required, to be volt free and wired in PARALLEL via normally open contacts to each terminal pair 'TIMER'. (Contacts closed to enable). Only heaters wired this way will respond to the enable signal. Note that all heaters on the network would have to be wired for BMS control and "external timer" must be selected from the engineers menu at the display panel.
- Door switches where required, to be volt free and wired to INDIVIDUAL base units via normally closed contacts to each terminal pair 'DOOR'. (Contacts open to enable door mode). Only heaters wired this way will respond to the door mode.



Display panel

Incoming three phase, neutral and earth cable (maximum 16mm<sup>2</sup>)  
The heater is supplied with a coverplate fitted to suit a 20mm SWA gland. Remove the coverplate to fit an M32 cable gland.



Incoming thermostat cable (maximum 7mm<sup>2</sup>)

Incoming RJ45 cable from controller

# Wiring Diagram

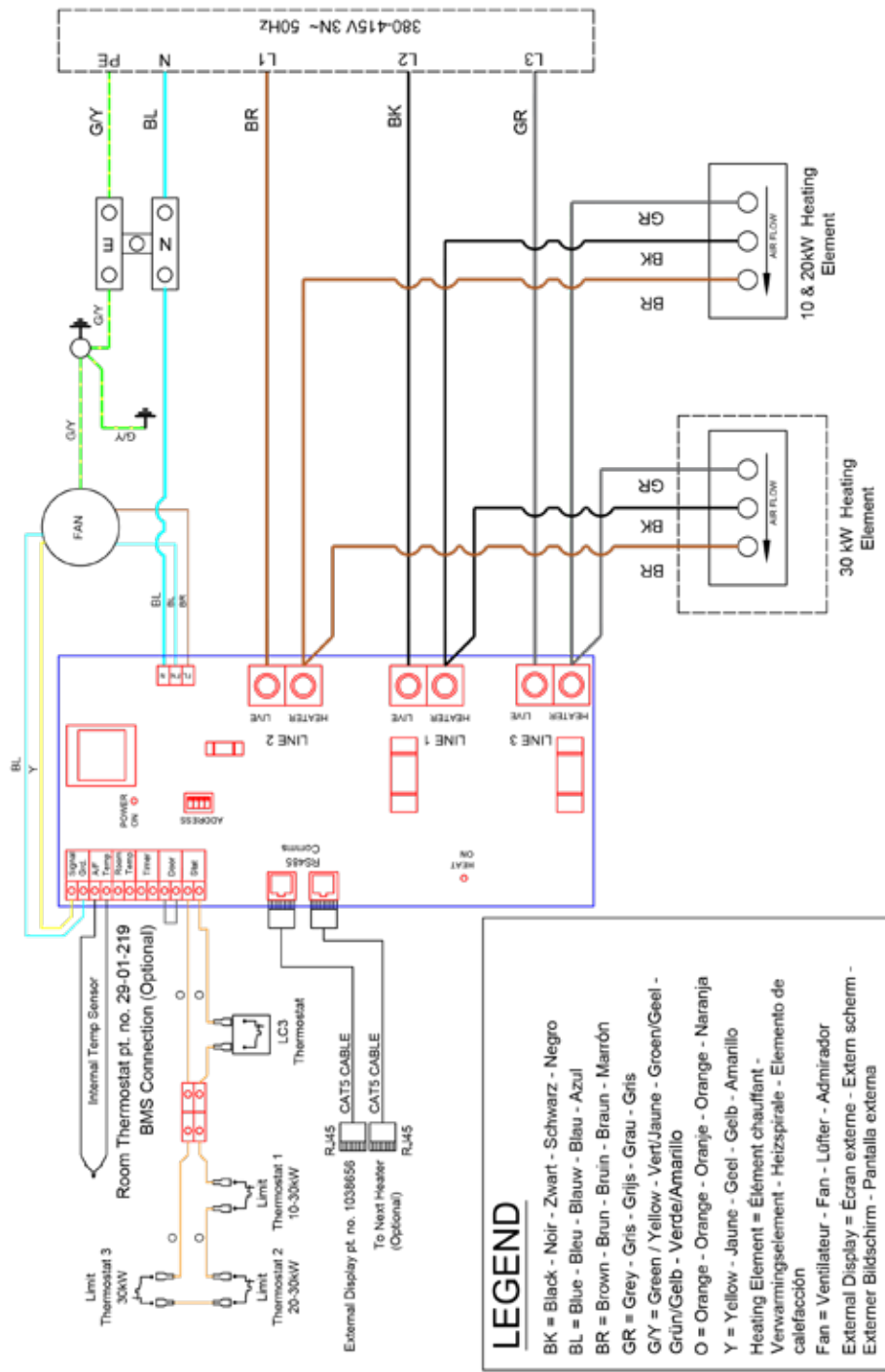

## Protection

There are two high speed fuses on the PCB board to protect the switching thyristors for the heater. An external circuit breaker with the appropriate rating should be installed for the protection of the installation

Terminal	Description	Cable
Timer	Optional external switch / BMS	1.5mm <sup>2</sup>
Door	Optional door contact	
Stat	External sensor	
PCB Fuses	Rating (A)	
F1	T1H (slow blow)	
F2 & F3	400v	

## Cable specification

# Controller, operation and commissioning

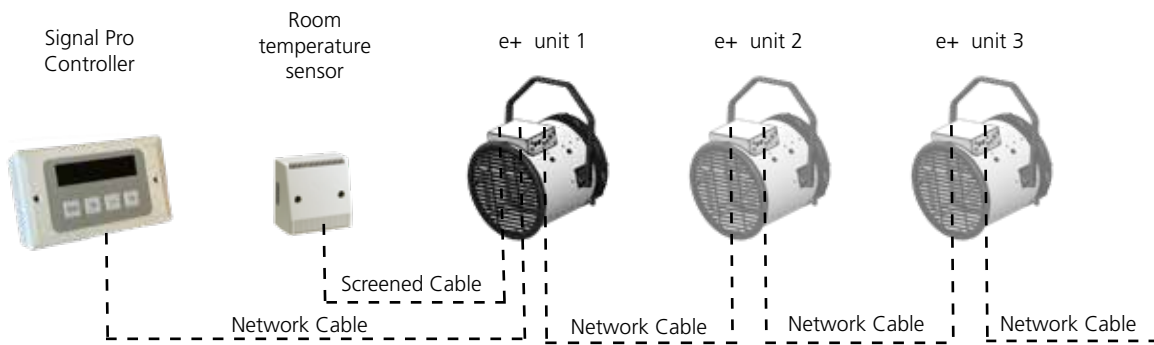

Up to a total of 16 heaters can be networked together to be controlled by one Signal Pro controller and a room temperature sensor (connected to the controller by 0.75mm<sup>2</sup> screened cable).  
At least one room temperature sensor is required - additional ones can be wired in to any of the other heaters in the network and the average temperature of those sensors will be used.

## Introduction

The function of the e+ Control is to operate the unit heater and fan to maintain a set air outlet temperature as measured by a temperature sensor.

The outlet set point, fan speed (1 or 2) and heat on signal is sent from the display panel to the e+ control board via an RS485 communication interface. The e+ control board returns data to the panel via the same communication interface.

Up to 16 e+ controls can be present on the RS485; each has an address that must be set via a 4-way DIP switch. The e+ control is a slave on the network and only transmits in response to a message from the panel which is the master.

Temperature sensors provide feedback on the heater output, monitor the PCB temperature for overheat and provide the panel with room temperature readings.

There are additional external inputs to the control which adjust the control behaviour namely: Timer switch, Door switch and Thermostat input.

The display panel has a microcontroller, a 16 character by 2 line display, 4 buttons and a communication interface. It also has a clock with battery back-up to provide time based control functionality. The display panel can be set to operate with different languages at the time of installation.

## Networking

The display panel is connected to the first heater via a pre-wired RJ45 cable to the socket in the first heater housing. A second heater can be connected to the first using a second RJ45 cable from the spare RJ45 socket of the first heater run to one of the RJ45 sockets in the second heater.

Further RJ45 cables can be used to connect more heaters to the network; up to a maximum of 16 heaters can be linked to one display panel.

10m, 30m and 50m lengths of RJ45 cable are available in the accessory kit (see page 17)



**Maximum network length 100m.  
(Total length of cable used between display panel and last heater in network).**

It is recommended that this control cable is run separately within its' own trunking if possible, to avoid external interference.

**Note: All heaters connected within the network system can be controlled under the user settings of the single display panel. See "engineers menu" to register all heaters in the network with the display panel.**

## Heater addressing

All heaters work on an address to communicate with the display panel and are supplied with a default address of '0'.

Where multiple heaters exist in a network they must be re-addressed using a unique address (0-9/A-F). This is achieved using the 4 way DIP switch [2] mounted on the control panel base unit PCB.

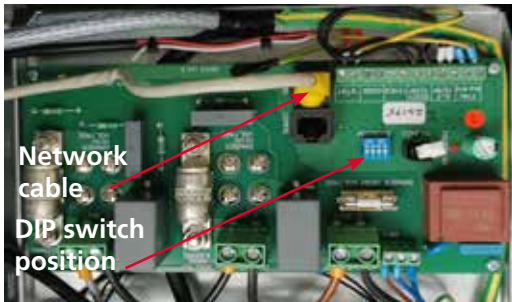

The display panel will check all addresses on first power up and the result will be displayed. All addresses will be viewed in rotation.

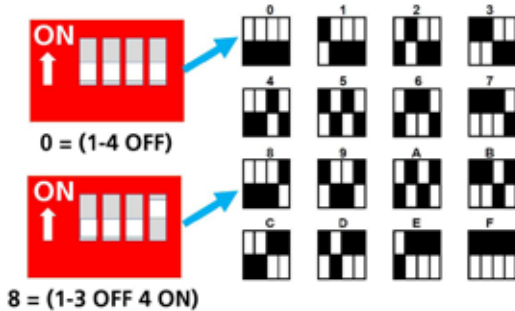

### DIP switch setting

Note: If any address is altered after initial power up or a heater is removed after initial installation, the display panel will also retain the original address although unable to respond. To remove an unwanted address, rescan the whole network in the manner detailed in Engineers instructions.

### Keypad buttons

The buttons have the following functions:-



- MENU enters the programming menu and advances item to program in order below.
- OK starts programming of visible item, value flashes during programming.
- PLUS and MINUS adjust the value.
- OK saves the modified value or MENU stops programming with value reverting to old value.

If more than one heater is connected to the network then for some settings all controls can be set together or controls can be set individually. Only controls that are present on the system can be programmed, others are skipped over. Heaters are addressed as 0 to 15 by the display, corresponding to bit switch settings 0 to F on the heater control.

It should be noted that from the normal operating display, the first press of the MENU button will cancel any Holiday, Overtime or Fan-Only Overtime that is operating.

### Set language

On first start up, the control panel will ask for a language to be set. The options are EN - English, FR - French, ES - Spanish, NL - Netherlands and DE - German.

### User menu

Press MENU button to enter User Menu.

1. Check temps. Displays average room temp, set day temp, set night temp. No PIN entry is required to display these temperatures.
2. Enter PIN, if enabled in Engineers
3. Set Overtime operation. Short term On operation, maximum set in Engineers.
4. Set Fan Only Overtime operation. Short term operation, maximum set in Engineers.
5. Set Holiday operation. Medium term Off/ Frost only operation.
6. Set Mode: Auto, Off Mode, Heat Only, Fan Only.
7. Set Clock, time and day.
8. Set Program, 3 On, 3 Off times. The default on/off times are 08.30 to 17.00 Monday to Friday.
9. Set Temperatures. On (day) temp, Off (night) temp. The default temperatures are 20°C day and 10°C night.
10. Menu end.

### Engineers menu

Press and hold '+' and then press MENU to enter Engineers Menu.

1. Enter PIN, if enabled in Engineers.
2. Set Internal or External Timer operation, system wide, overrides time program.



3. Enable Night operation, system wide.
4. Enable Frost operation, system wide, fixed 5°C.
5. Set Outlet Temperature, per heater, 1, 2 or 3 default 2 (see technical details earlier).
6. Set Fan Speed, per heater, default 1, 1 or 2.
7. Set Bandwidth, system wide, range 2 ~ 10°C, default 2°C. See figure 1. Set Bandwidth Taper, range 2 ~ 20°C, default 5°C. Set Deadband, system wide, range 2 ~ 10°C, default 2°C.
8. Set sensor offset, per heater with room sensor, range -5 ~ +5°C.
9. Set Overtime maximum, system wide, range 0 ~ 10 hours, default 1 hour.
10. Set Fan Only maximum, system wide, range 0 ~ 10 hours, default 1 hour.
11. Set Optimum Start time, system wide, range 0 ~ 240 mins, default 0 mins.
12. Set Optimum Stop time, system wide, range 0 ~ 120 mins, default 30 mins.
13. Display hours run per heater.
14. Set Language. EN, FR, ES, NL, DE.
15. Heater address scan.
16. Factory Reset.
17. PIN protection, On/Off.
18. Set PIN.
19. Engineer Menu end.

### Diagnostic display

Press and hold '+' and '-' then press MENU to enter diagnostic mode. A display of the following is given per heater:-

1. Heater ID, 0 to 15
2. Config, 'C': 0 error, 1-3 is 10 to 30kW, 'd' is development.
3. Heat, 'H': 0/1 is on/off.
4. Fan, 'F': 0/1 is on/off.
5. Heating element output power: xxx%.
6. Room temperature, Rttt = tt.t°C, 'xxx' sensor out of range, '---' no sensor fitted.
7. Outlet air temperature, Ttt = tt°C, 'xx' sensor out of range.

8. PCB temperature, Ptt = tt°C, 'xx' sensor out of range.
9. Limit Stat open circuit, 'S' = open circuit (fault, heat off).
10. External door input, 'D' = open circuit (door open).
11. External input, 'T' = open circuit (timer off).

### Normal operation

Under normal operation, the panel will display an address scan every time the panel starts. Once the address scan has been displayed, the panel will show on an alternating basis:-

- Panel status:
  - day and time or external BMS
  - on / off period
  - optimum start / stop
  - overtime or fan only with remaining time
  - holiday with remaining days
  - message for holiday pending, battery low, no battery, no room sensor(s)
- Heater status (per networked heater):
  - Heater number: 0 ~ 15.
  - Heater function: Off, Heat, Fan
  - Heater status: Door Open, Over Temp Error, Temp Sensor Error, Comms Error.

### Features

The controller provides the following features:-

- Auto mode: fully automatic control of heating and fan-only to time program using On (day) temp and Off (night) temp. In On periods heat and fan-only. In Off periods heat only.
- Off mode: only heats if below 5°C. If Frost is disabled, in Engineers settings, then absolutely no heating.
- Heat Only: automatic control of heating to time program using On (day) temp and Off (night) temp.
- Fan Only: automatic control of fan-only (no heat) to time program using On (day) temperature. No fan-only in Off periods.
- Overtime: heats to On (day) temperature, no fan-only, for the number of hours and minutes set. If overtime is set then if Menu is pressed the overtime is cleared immediately.



- Fan Only Overtime: runs fan-only to On (day) temperature, no heating, for the number of hours and minutes set. If fan-only overtime is set then if Menu is pressed the fan-only overtime is cleared immediately.
- Optimum Start: starts heating before an upcoming On period, time depends on temperature raise to Day Temp, historical heat-up times and Optimum Start maximum time set in Engineers (default 60 minutes).
- Optimum Stop: stops heating before an upcoming Off period, time depends on historical cool-down times and Optimum Stop maximum time set in Engineers (default 30 minutes). Control will not allow the temperature to drop more than 2°C in this period.
- Holiday: When holiday is set the system operates with Off mode for the number of days set. Holiday starts at midnight on the day it is programmed and counts down one day every midnight thereafter. If holiday is set then if Menu is pressed the holiday is cleared immediately.
- Hysteresis on setpoint is +0.5°C, i.e. heat to Set Point + 0.5°C then cool to Set Point. The heater output temperature is adjusted using the algorithm shown at the end of this section.
- Under Engineers Settings, the timer mode can be set to external/BMS where the control will ignore the time program and control to On/Day temperature when Timer input is closed and Off/Night settings when the Timer input is open. All controls on the network will be controlled from one Timer input. Usually only one heater will have a Timer input, other heaters should be left with the input open-circuit as the panel will respond if any of the Timer inputs is closed-circuit.
- Room Sensor: If no room sensor is present on the system the heaters will be off and panel will display an error message. If one room sensor is present on the system then that will be used for all heaters. If more than one room sensor is fitted (multiple heaters only), then Signal Pro averages these sensors.
- Heater outlet temperatures are fixed based on the heater rating, the set fan speed and the programmed heat level, as shown in the technical data tables.

### Configuration program key

A program key has been provided for the unit heater to set the type and rating of the control, and the fan speeds. The chart below details the various keys.

Key	Application
No Key	Control will not run. Error signal at panel
22k Ohm	10kW heater
15k Ohm	20kW heater
10k Ohm	30kW heater

### Fan Speeds

Pre-programmed fan speed outputs are:-

Heater	Speed 1	Speed 2
10kW heater	4.2V	5.5V
20kW heater	7.6V	10.0V
30kW heater	8.8V	10.0V

### Temperature sensors

Three separate temperature sensors have been provided at the unit heater:-

- Air outlet temperature - Thermistor bead mounted at outlet grille. Used by the controller as feedback to adjust heat level to achieve desired outlet air temperature.
- Room temperature - Thermistor bead inside 'thermostat' case, uses SC3 room sensor. Measurement range -10°C to 50°C. Not directly used by control, but used by remote control panel.
- PCB temperature - Thermistor bead mounted to PCB near to thyristor connections. Used by control for protection of control and components.

## Thermal cut-out

When either thermal cut-out is open circuit the fan output is set to maximum, 10V, and the heating is forced off although it may continue to heat if the triacs or drive circuit fail, hence the maximum fan speed.

If the thermal cut-out returns to a closed state the fan will continue to operate at 10V until the mains is turned off.

**C** Thermal cut-out has the highest priority and overrides all other operation modes. An error message will be given at the display panel.

## Timer / BMS input

The Timer / BMS input has no direct effect on the heater however, the signal is passed to the panel for action. At the panel, in Engineers settings, the timer mode can be set to external/ BMS where the control will ignore the time program and control to On/Day temperature when the Timer input is closed and Off/Night settings when the Timer input is open. All controls on the network will be controlled from one Timer input. Unused Timer inputs should be left open-circuit.

## Door / Off input

When the Door/Off input is closed-circuit the controller operates to the time and temperature settings sent from the panel.

When the Door input is open-circuit the heater is forced off, this will override any settings from the panel, including frost protection.

Door input only affects the heater it is connected to. Door/Off input status is sent to the panel for information.

On delivery the electric heater controls will have a link fitted to disable Door/Off input.

## Network data format and data protocol

Please refer to the separate Modbus parameters manual for full details.

## Commissioning - start up

Once the unit has been installed in the manner described earlier in this manual, the unit can be commissioned as follows:-

1. Turn on the electrical supply to the heater.
2. Set up the controller in the manner described earlier.
3. Set the thermostat to its' highest setting.
4. Check the operation of the heater.
5. Set the thermostat to the required room temperature.

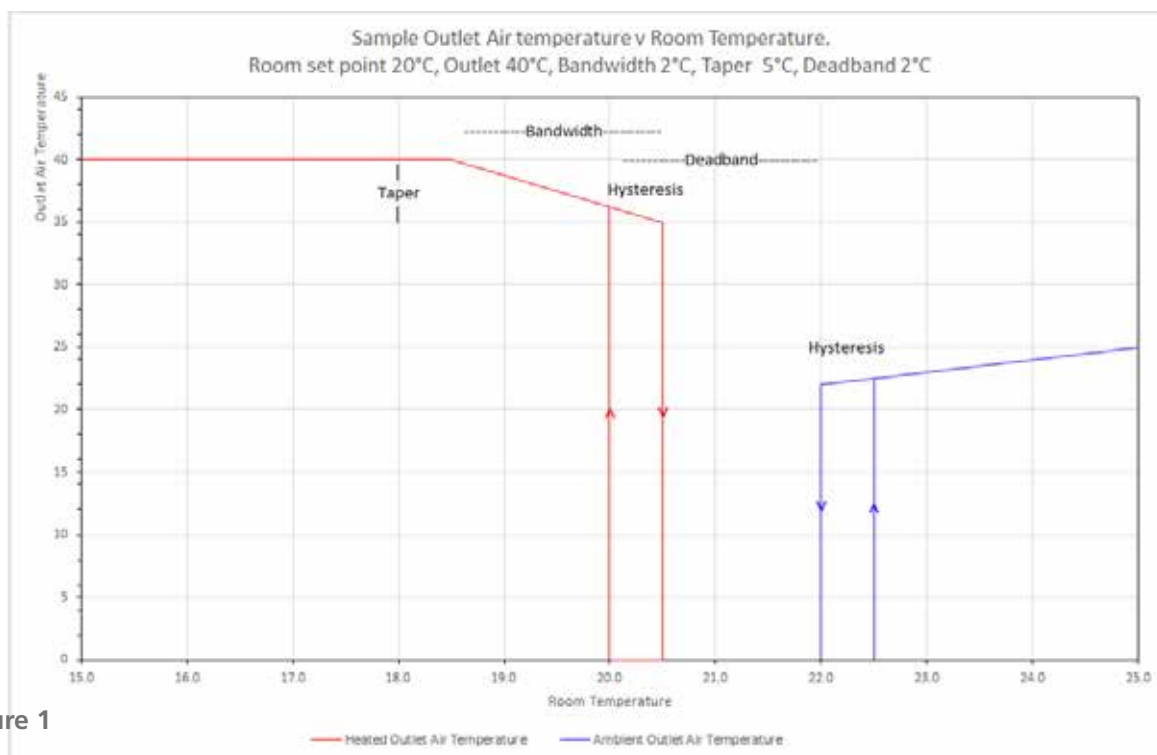

## Commissioning - handover

Upon full and satisfactory completion of commissioning, a record of commissioning information and a copy of this manual should be left with the person responsible for the heater. The commissioning engineer must ensure that the user is familiar with the safe and efficient use of the heater, detailing the function of all controls and main components.

The user should be made aware of the following in particular: -

1. Starting, shutdown, and operational information.
2. Safety features, data plate, and labelling.
3. How to reset the heater in the event of a high temperature lockout
4. The requirement for regular inspection - especially if the heater is within a more demanding environment - and the need for regular servicing carried out by a suitably qualified person.

## Operation

Once the unit has been commissioned, the heater will run fully under the dictates of the room thermostat and the controller.

During summer periods or at times when the room space ambient temperature is higher than the set temperature, the unit will automatically operate to provide ventilation only.

## Overheat protection

In the event of the fan failing to run, a thermal cut-out will operate. This will auto-reset once the element has cooled.

In the event of the fan running at a reduced air flow rate, a limit control thermostat (LC3) switches off the heater to a lockout condition.

In either situation, an overheat error message will be given at the display panel, requiring a thorough check of the unit and a recycle of the power supply to the unit to reset the panel.

If the LC3 stat has tripped it must be manually reset. A cooling time of about 3 minutes is necessary before resetting. The LC3 reset switch is located on the top of the unit between the main fan assembly and the control section access lid as shown below.



In the event of either the element thermal cut-out or the limit control thermostat operating, the power supply to the heater must be cycled (switched off then on again). This will clear the display and return the heater to its' working state.



**In order to avoid a hazard due to inadvertent resetting of the thermal cut-out, this appliance must not be supplied through an external switching device, such as a timer, or connected to a circuit that is regularly switched on and off by the utility.**

# Maintenance



**Always ensure that the electricity supply to the heater is isolated before commencing any maintenance on the unit heater. Lock and tag the isolator switch.**

**Ensure that the heater has cooled down before carrying out any maintenance or repair activities.**

**Do not clean the inside of the unit with water. A soft brush should be used.**

**To obtain the best results from the heater, it is essential to avoid the accumulation of dust and dirt within the unit on the air inlet and discharge grilles and the heating element. For this reason, regular cleaning is necessary, paying particular attention to the removal of dirt build up on the fan and heating element assembly.**

MS



## General Maintenance

The product must be serviced annually, by a competent person. The following actions should be undertaken as part of the service:-

- Check the security of the heater supports and hanging bracket.
- Clean the unit casing, fan guard, fan blades and motor once a year. A dirty motor will tend to run hot and eventually will be damaged internally. Any rust spots on the casing should be cleaned and repainted.
- Clean the inside of the heater including the heating elements and temperature sensor.
- Inspect the heating elements and replace if damaged.
- Inspect the control panel wiring and electrical connections to make certain the insulation is intact and all connections are tight.
- Inspect all heater and relay contacts. If the contacts appear badly pitted or burned, replace the contactor / relay.
- Check operation of the controls.

Fan and motor bearings are of the "sealed for life" type and do not require maintenance other than replacement upon failure.

## Removal of grille

To remove the front grille for access to the safety thermostat and heating element:-

1. Remove the M6 Torx bolts around the perimeter of the grille.
2. The grille will now slide off. Take care not to damage the LC3 limit stat cabling.
3. Refit the grille in the reverse order, again taking care not to damage the LC3 limit stat and thermistor bead cabling.



## Removal of heating element

To remove the heating element:-

1. Remove the grille in the manner detailed above
2. Unclip the limit stat bracket from the inner face of the grille. To avoid the limit stat bracket hanging loose, use one of the grille fixing bolts and holes to fasten the bracket to the unit casing.
3. Undo the cable connections to the heater inside the casing. Note that there are two sets of cables that have to be disconnected from the heating element.



4. Remove the M6 Torx bolts holding the element to the unit casing, including the earthing cable.

- Remove the element from the unit using the handles on the element frame.

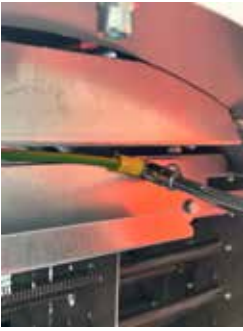

- Replace and connect the element in the reverse order.
- Replace the grille taking care not to damage the limit stat and thermistor bead cables.

### Replacement of LC3 limit thermostat

To replace the LC3 limit thermostat:-

- Remove the grille in the manner detailed above.
- The sensor bracket is held onto the inner face of the grille with steel clips. Unclip the sensor bracket from the inner face of the grille.



- The limit stat is held onto the bracket with a steel clip. Carefully unclip the limit stat from the bracket.
- Remove the heating element in the manner described previously.
- Remove the holding nut on the limit stat reset button and push the button inside the unit.



- Disconnect the two orange cables from the reset button, insert the limit stat bulb into the black cable support conduit then pull the white cables and limit stat through the conduit to remove.

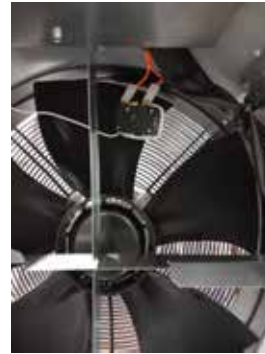

- Reverse the process to replace the limit stat. Ensure that the limit stat is located in the correct position as shown in "locating the sensors and sensor bracket" overleaf.
- Follow the steps given in "locating the sensors and sensor bracket" overleaf.

### Replacement of thermistor

To replace the thermistor:-

- Remove the grille in the manner detailed above.
- The sensor bracket is held onto the inner face of the grille with steel clips. Unclip the sensor bracket from the inner face of the grille.
- The thermistor bead is held in place on the sensor bracket with a screw. Unscrew this sufficiently to withdraw the sensor bead from the bracket.
- Open the heater control compartment on top of the heater. The cover is hinged, held in place with one M6 Torx bolt.
- Disconnect the thermistor cables from the PCB.
- Holding the thermistor bead, pull the cables through the unit to remove.
- Reverse the process to replace the thermistor.
- Follow the steps given in "locating the sensors and sensor bracket" overleaf.

MS

## Locating the sensor bracket and sensors

It is vitally important to the operation of the unit that the LC3 limit stat and thermistor bead are located in the correct position on the sensor bracket. The positions are shown below.

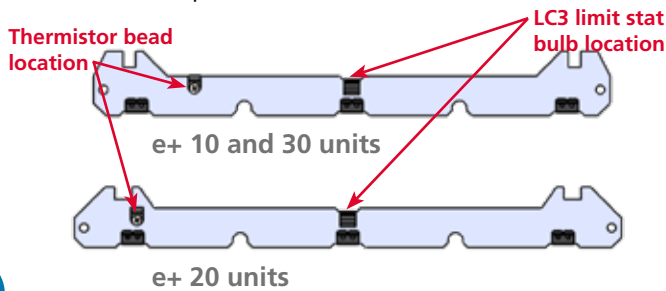

MS

It should be noted that the thermistor bead **MUST** protrude by 13mm from the fixing screw. The image below shows the correct fixing locations for both the thermistor bead and the LC3 limit stat bulb.



In turn, it is vitally important that the sensor bracket is located in the correct position. For e+ 10 and e+ 30 units, the bracket must align with the sixth louvre blade from the top of the grille. For e+ 20 units, the bracket must align with the tenth louvre blade from the top of the grille. A vertical bracket has been provided to the left of the unit to assist in this alignment as shown below.



To locate the sensor bracket:-

1. Align the notch on the left hand side of the sensor bracket with the notch in the vertical bracket as shown.
2. Refix and screw the grille in place. Note that the grille will not sit correctly unless the notches have been aligned.

## Removal of fan

To remove the fan:-

1. Open the heater control compartment on top of the heater. The cover is hinged, held in place with one M6 Torx bolt.
2. Disconnect the fan cables from the PCB.
3. The cables run in clips along the outside of the casing. Unclip the fan cables.
4. Remove the fan holding bolts.
5. Remove the fan from the casing.
6. Replace the fan in the reverse order.

## Removal of PCB controller

To remove the controller:-

1. Open the heater control compartment on top of the heater. The cover is hinged, held in place with one M6 Torx bolt.
2. Disconnect all cables from the PCB.
3. Unscrew the two M4 bolts on the left of the PCB tray as indicated below.
4. Lift the left hand side of the PCB tray.
5. Unscrew the PCB from the tray and remove the PCB.
6. Replace the PCB in the reverse order.

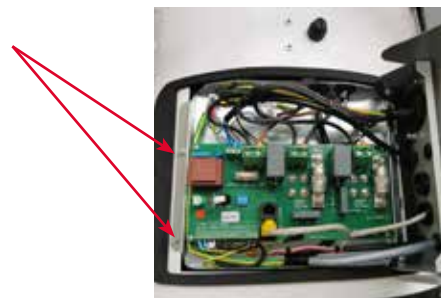



This page is intentionally blank

# Fault Finding

---

## General

All electric unit heaters are fitted with fuse protection and motor thermal protection.

Faults in relation to the element, motor and wiring should be identified using conventional fault-finding techniques and the table below.

In the event that electrical components are replaced, please ensure that electrical safety checks in accordance with the regulations in force in the country of use are undertaken.

Note that there is a thermal cut-out incorporated in the electric unit heater which needs to be manually reset. The cut-out is located on the top of the unit towards the fan.

Re-setting the thermal cut-out may help to identify the nature of the fault however we do not recommend re-setting without a thorough investigation into why the cut-out operated.

FF

## Display panel

Any fault will be described on the display panel until the fault has been cleared.

There are five basic checks to perform should a fault appear on the program panel display. These are as follows:

- **Continuity:** Use a multimeter to check continuity between each end of the cable cores.
- **Short circuit:** Use a multimeter to check that there are no short circuits between any of the cable cores.
- **Plugs:** Check that the plugs are firmly seated in the circuit board sockets in both the program panel and on the circuit board .
- **Addressing:** (Network versions only). If two or more unit heaters are networked, check that each unit has a unique address as described in network addressing on page 23.
- **Network cables:** Ensure that the total run of all cables in the network does not exceed 100m including the cable to the program panel.



<b>Fault</b>	<b>Possible Cause</b>	<b>Remedy</b>
Thermostat calls for heat, but heater does not function	Blown fuse	Replace fuse after checking the cause
	Wiring fault	Check wiring connections
	Thermal cut-out activated	Check that the supply voltage is correct
		Check the control wiring is correct
		Check that there has not been a power supply interruption during unit operation
Ensure there is no restriction to airflow through the heater		
Fan motor runs HOT	Dust accumulation or excessive dirt on fan/motor assembly	Clean fan/motor assembly
	Dirt accumulation	Clean louvres
	Fan/motor assembly problem	Investigate and replace fan/motor assembly if necessary
Fan operating, no heat	Air sensor cable disconnected	Check cable connection
	Air sensor failed	Replace air sensor
	Overheat stat open circuit	Reset overheat stat
		Replace overheat stat if failed
	High ambient air temperature	Check ventilation to area
	Incorrect motor / fan rotation	Check rotation of the fan / motor
Motor failure	Check motor and replace if necessary	
No control at unit	Poor data cable connection	Check data cable and plugs
	Damaged data cable	Replace damaged data cable



## Spare Parts

Description	e+ 10	e+ 20	e+ 30
Axial Fan	1038556		1038651
Element Assy	1038671-S	1038672-S	1038673-S
Control Board	1038558		
Resistor Key	1031720	1031719	1031718
Wiring Harness	1038653		1038654
LC3 Limit Stat	1031960	03-24959	03-24959-03
Outlet Grille	1038519		
Thermistor	1038737		
Sensor clip set *1	1038738		
Controller Display *2	1038656		
Room Thermostat *2	29-01-219		
Controller kit with 10m RJ45 cable *2	EUH-CTRL-KIT-10M		
Controller kit with 30m RJ45 cable *2	EUH-CTRL-KIT-30M		
Controller kit with 50m RJ45 cable *2	EUH-CTRL-KIT-50M		

SP

### Notes:

- \*1 The sensor clip set contains the following:
  - 3-off - 1038702 (S-Clip for LC3 bracket)
  - 1-off - 1038717 (P-clip for thermistor)
  - 1-off - 5259 (Screw for thermistor clip)
  - 1-off - 5016006 (Clip for LC3 bulb)
- \*2 A controller display and room thermostat are included in the controller kit, along with an applicable length of RJ45 cable

# Exploded view

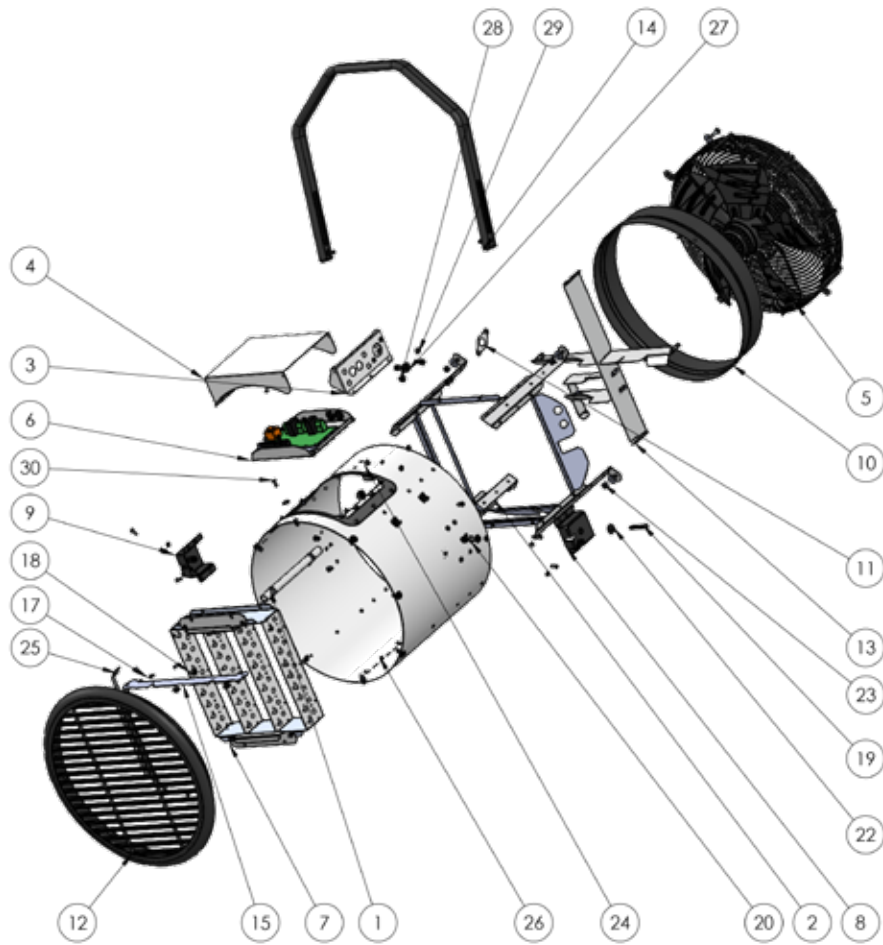

1	e+ body assembly	16	S clip
2	Heater element support assembly	17	P clamp
3	Access cover fixed mount	18	Cable clip for LC3
4	Hinged access cover panel	19	Button head screw
5	EC axial fan and motor	20	Shoulder bush
6	Electrical panel assembly	21	M8 form A
7	Heater element	22	M8 rubber washer
8	Pivot bracket left	23	Nyloc nut
9	Pivot bracket right	24	Limit control stat LC3
10	Fan adapter	25	Sensor vertical locating bracket
11	Cable gland adapter 20mm	26	Pop rivet
12	Flat slats louvre	27	Cable bush
13	Baffle assembly	28	Cable snub bush
14	Hanging bracket	29	Blind grommet
15	Sensor fixing bracket	30	Torx screw

Warm Air ErP Data Table 415V	Test Engineer:	DFW	DEV-037	Version	1.0	Date:	08/05/24
<b>Information requirements for warm air heaters Commission Regulation (EU) 2018</b>							
B1 warm air heater:	[NO]						
C2 warm air heater:	[NO]						
C4 warm air heater:	[NO]						
Type of fuel:	Electricity						
Model:							
Fuel (for data selection only)							
Fan Speed (FX)							
Heat Setting (HX)							
Item:	Symbol:	Units:					
Capacity:							
Rated heating capacity:	P <sub>nom</sub>	[kW]	10.8	21.5	32.3	10.8	21.5
Minimum capacity:	P <sub>min</sub>	[kW]	2.1	3.3	5.0	3.9	5.6
Electric power consumption:							
In standby mode:	elsb	[kW]	0.001	0.001	0.001	0.001	0.001
Other items:							
Envelope loss factor:	F <sub>env</sub>	[%]	0.0	0.0	0.0	0.0	0.0
Emission efficiency:	η <sub>s,flow</sub>	[%]	97.4%	97.0%	97.0%	96.3%	94.8%
ErP seasonal space heating energy efficiency:	η <sub>s</sub>	[%]	38.9%	38.8%	38.8%	38.1%	37.2%
Contact details:	Nortek Global HVAC (UK) Ltd Fens Pool Avenue Brierley Hill West Midlands DY5 1QA						
NOTE: Seasonal Efficiency based on appliance running with a room temperature setpoint of 20.0°C (R200).							
<b>Information requirements for warm air heaters Commission Regulation (EU) 2018</b>							
B1 warm air heater:	[NO]						
C2 warm air heater:	[NO]						
C4 warm air heater:	[NO]						
Type of fuel:	Electricity						
Model:							
Fuel (for data selection only)							
Fan Speed (FX)							
Heat Setting (HX)							
Item:	Symbol:	Units:					
Capacity:							
Rated heating capacity:	P <sub>nom</sub>	[kW]	10.8	21.5	32.3	10.8	21.5
Minimum capacity:	P <sub>min</sub>	[kW]	2.5	3.8	5.5	4.0	5.5
Electric power consumption:							
In standby mode:	elsb	[kW]	0.001	0.001	0.001	0.001	0.001
Other items:							
Envelope loss factor:	F <sub>env</sub>	[%]	0.0	0.0	0.0	0.0	0.0
Emission efficiency:	η <sub>s,flow</sub>	[%]	97.6%	97.2%	97.1%	96.7%	95.8%
ErP seasonal space heating energy efficiency:	η <sub>s</sub>	[%]	39.0%	38.9%	38.8%	38.2%	37.9%
Contact details:	Nortek Global HVAC (UK) Ltd Fens Pool Avenue Brierley Hill West Midlands DY5 1QA						
NOTE: Seasonal Efficiency based on appliance running with a room temperature setpoint of 20.0°C (R200).							



Warm Air ErP Data Table 380V	Test Engineer:	DFW	DEV-037	Version	1.0	Date:	08/05/24
<b>Information requirements for warm air heaters Commission Regulation (EU) 2018</b>							
B1 warm air heater:	[NO]						
C2 warm air heater:	[NO]						
C4 warm air heater:	[NO]						
Type of fuel:	Electricity						
Model:		<b>EUH10</b>	<b>EUH20</b>	<b>EUH30</b>	<b>EUH10</b>	<b>EUH20</b>	<b>EUH30</b>
Fuel (for data selection only)		380	380	380	380	380	380
Fan Speed (FX)		F1	F1	F1	F1	F1	F1
Heat Setting (HX)		H1	H1	H1	H2	H3	H3
Item:	Symbol:	Units:					
<b>Capacity:</b>							
Rated heating capacity:	P <sub>nom</sub> [kW]	9.0	18.1	27.1	9.0	18.1	27.1
Minimum capacity:	P <sub>min</sub> [kW]	2.1	3.3	5.0	3.9	8.6	13.2
<b>Electric power consumption:</b>							
In standby mode:	elsb [kW]	0.001	0.001	0.001	0.001	0.001	0.001
<b>Other items:</b>							
Envelope loss factor:	F <sub>env</sub> [%]	0.0	0.0	0.0	0.0	0.0	0.0
Emission efficiency:	η <sub>s,flow</sub> [%]	97.6%	97.3%	97.3%	96.5%	95.1%	93.0%
ErP seasonal space heating energy efficiency:	η <sub>s</sub> [%]	39.0%	38.9%	38.9%	37.7%	36.8%	34.0%
Contact details:	Nortek Global HVAC (UK) Ltd Fens Pool Avenue Brierley Hill West Midlands DY5 1QA						
NOTE: Seasonal Efficiency based on appliance running with a room temperature setpoint of 20.0°C (R200).							
<b>Information requirements for warm air heaters Commission Regulation (EU) 2018</b>							
B1 warm air heater:	[NO]						
C2 warm air heater:	[NO]						
C4 warm air heater:	[NO]						
Type of fuel:	Electricity						
Model:		<b>EUH10</b>	<b>EUH20</b>	<b>EUH30</b>	<b>EUH10</b>	<b>EUH20</b>	<b>EUH30</b>
Fuel (for data selection only)		380	380	380	380	380	380
Fan Speed (FX)		F2	F2	F2	F2	F2	F2
Heat Setting (HX)		H1	H1	H1	H2	H3	H3
Item:	Symbol:	Units:					
<b>Capacity:</b>							
Rated heating capacity:	P <sub>nom</sub> [kW]	9.0	18.1	27.1	9.0	18.1	27.1
Minimum capacity:	P <sub>min</sub> [kW]	2.5	3.8	5.5	4.0	7.6	11.3
<b>Electric power consumption:</b>							
In standby mode:	elsb [kW]	0.001	0.001	0.001	0.001	0.001	0.001
<b>Other items:</b>							
Envelope loss factor:	F <sub>env</sub> [%]	0.0	0.0	0.0	0.0	0.0	0.0
Emission efficiency:	η <sub>s,flow</sub> [%]	97.8%	97.4%	97.4%	96.9%	96.0%	94.5%
ErP seasonal space heating energy efficiency:	η <sub>s</sub> [%]	39.1%	39.0%	39.0%	37.7%	37.6%	35.6%
Contact details:	Nortek Global HVAC (UK) Ltd Fens Pool Avenue Brierley Hill West Midlands DY5 1QA						
NOTE: Seasonal Efficiency based on appliance running with a room temperature setpoint of 20.0°C (R200).							

# Notes

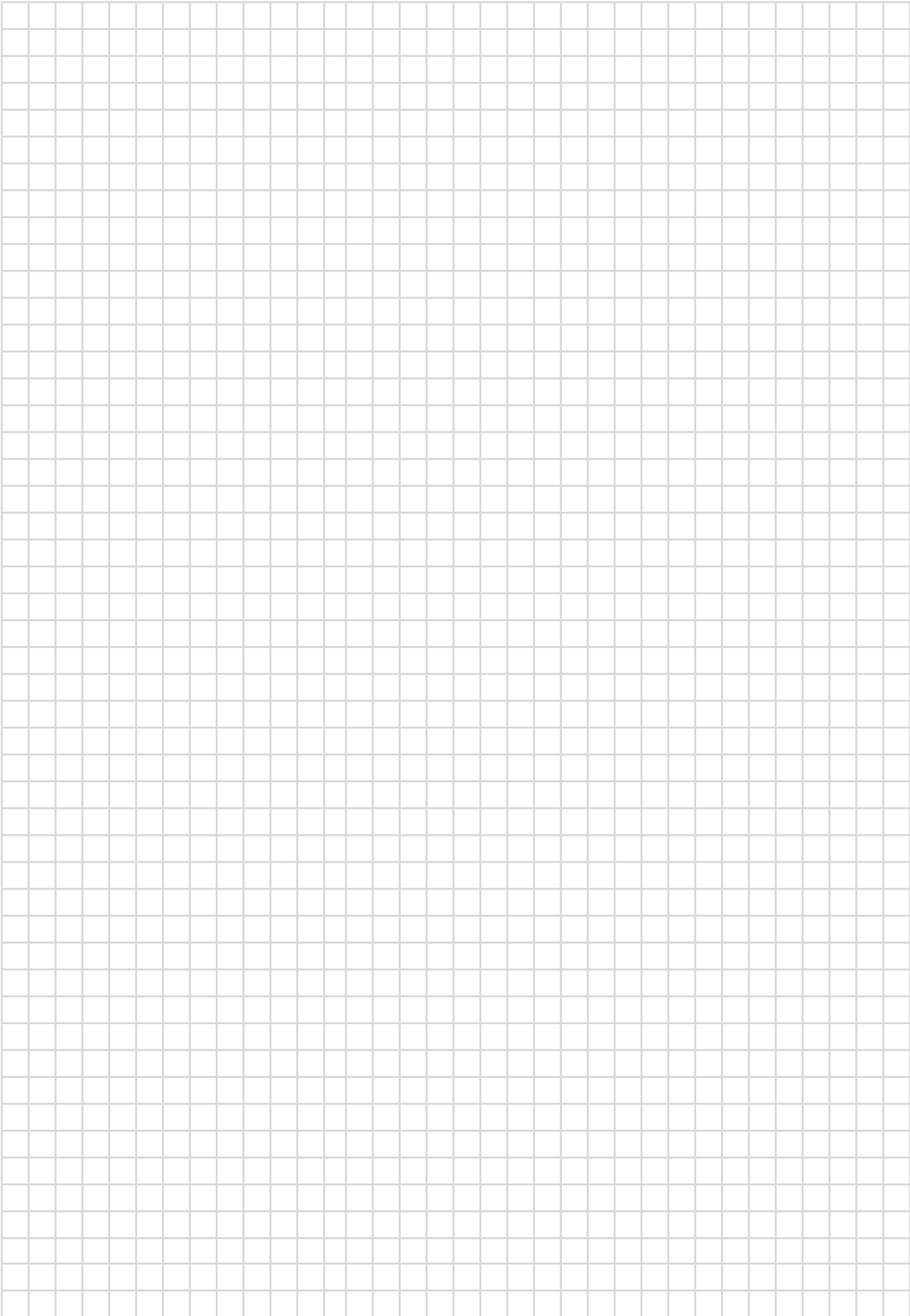



**NORTEK GLOBAL HVAC (UK) LTD**

Fens Pool Avenue  
Brierley Hill  
West Midlands DY5 1QA  
United Kingdom  
Tel +44 (0)1384 489700  
Fax +44 (0)1384 489707  
vapacsales@nortek.com  
www.vapac.com

Nortek Global HVAC is a registered trademark of Nortek Global HVAC limited. Because of the continuous product innovation, Nortek Global HVAC reserves the right to change product specification without due notice.