

# Vapac

## VIRTUOSO VE ELECTRODE BOILER HUMIDIFIER



### INSTALLATION AND OPERATING MANUAL



This product meets the following UK Designated Standards:

Electrical Equipment (Safety) Regulations 2016

Electromagnetic Compatibility Regulations 2016

The Restriction of the Use of Certain Hazardous Substances in Electrical and Electronic Equipment Regulations 2012

Please read this document carefully before commencing installation, commissioning and/or servicing.  
Leave it with the end user/site agent to be placed in their premises technical file after installation.

#### WARNING

Improper installation, adjustment, alteration, service or maintenance can cause property damage, injury or death.

All work must be carried out by appropriately qualified persons.

The manufacturer does not take any responsibility in the event of non-observance of the regulations concerning the connection of the apparatus causing a dangerous operation possibly resulting in damage to the apparatus and/or environment in which the unit is installed.

# Contents

---

## General Information (G)

---

Virtuoso VE range .....	4
Using this manual .....	4
Warranty .....	4
Important notice to installers .....	5
Health and safety .....	6

## Technical (TD)

---

Technical data and dimensions .....	8
Clearances .....	9

## Installation (I)

---

Uncrating / preparation .....	10
List of accessories supplied .....	11
Humidifier location .....	12
Mounting the humidifier .....	12
Cold water supply and drainage .....	15
Cold water supply .....	16
Water drain connections .....	17
Mounting the steam pipe(s) .....	18
Guide to positioning steam pipes .....	20
Electrical supply and connections .....	24
Control input connections .....	25
Safety circuit / emergency shutdown .....	25
Volt free outputs .....	25
Wiring diagrams .....	25
Touch screen display panel .....	26
Initial startup mode .....	26
1. Starting up please wait .....	26
2. Setting system time and date .....	26
Normal operating mode .....	26
1. Standby mode .....	27
2. Steaming mode .....	27
3. Filling mode .....	27
4. Draining mode .....	27

5. Caution alarm .....	27
6. Double cylinder units .....	28
7. Mode selection .....	28
8. Select language / change time .....	28
Commissioning Mode .....	28
1. Commissioning mode page 1 .....	29
2. Commissioning mode page 2 .....	29
3. Commissioning mode page 3 .....	30
4. Commissioning mode page 4 .....	30
5. Commissioning mode page 5 .....	31
Critical alarm .....	31
Service and advanced modes .....	31
Service due indication .....	31
Cylinder selection .....	32
Cylinder electrical demand loads .....	33

## Commissioning and Operation (C)

---

Pre-start checks .....	36
Start up .....	36
Commissioning checks .....	37
Commissioning - handover .....	37
Operation .....	37
Operational status indication .....	38
Unit frost protection .....	38

## Maintenance and Servicing (MS)

---

Maintenance schedule .....	40
Steam cylinder replacement .....	40
Cleanable steam cylinders .....	41
Steam hoses .....	41
Tundish .....	42
Feed valve with strainer .....	42
Bottom access panel .....	42
Drain pump and feed / drain manifold .....	43

## **Fault Finding (FF)**

---

General fault finding.....	44
SSR fault finding .....	45

## **Spare Parts (SP)**

---

Spare parts. ....	46
Electrical Components .....	47
Mechanical Components .....	48
Model VE05-1P, VE09-1P, VE09-3P VE18-3P, VE30-3P, VE45-3P .....	48
Model VE6 0-3P, VE90-3P .....	49
Taking the unit out of operation.....	50
Decommissioning / disposal .....	50

## **Appendices (A)**

---

A1 Wiring diagram single phase units .....	52
A2 Wiring diagram three phase single cylinder units .....	58
A3 Wiring diagram three phase double cylinder units .....	64

## Virtuoso VE Range

### General product information

Virtuoso VE is the latest generation of electrode boiler steam humidifiers, being suitable for both comfort ( $\pm 10\%$  rh) and close control ( $\pm 5\%$  rh) applications. The units incorporate an intelligent combination of feeding, boiling and draining to operate efficiently and minimise wastage of both water and energy.

An optional room distribution unit is available for VE05 and 09 models, directly fixing to the humidifier or remotely mounted within the room ([see separate manual D301511](#)).

This installation manual is shipped with the appliance. Verify that the literature is correct for the model being installed. If the manual is incorrect for the humidifier, contact the supplier before starting installation. The instructions in this manual apply only to the models listed within.

Installation should only be carried out by a suitably qualified installer in accordance with these instructions and the current rules and regulations in force. The installer is responsible for the safe installation of the humidifier.

### Using this manual

The symbols for 'Caution' and 'Warning' are used to highlight certain points throughout this manual.



**Caution is used when failure to follow or implement the instruction(s) can lead to premature failure or damage to the humidifier or its component parts.**



**Warning is used when failure to take note of or implement the instruction(s) can lead to not only component damage, but also to a hazardous situation being created where there is a risk of personal injury.**

### Warranty

This equipment comes as standard with a manufacturers 12 month warranty from the date of purchase unless otherwise agreed with the distribution partner. The warranty is void if:

1. The installation is not in accordance with these instructions.
2. Wiring is not in accordance with the diagrams included in this manual.
3. The unit is installed without proper clearances wherever clearances are required.
4. The unit has not been serviced and maintained in accordance with the information contained within these instructions.
5. The steam delivery system is modified in any way.



**Ignoring the warning and caution notices and the advice from the manufacturer on installation, commissioning, servicing or use, will jeopardise any applicable warranty. This could also compromise the safe and efficient running of the appliance itself and thereby constitute a hazard.**

**The electrical isolator should only be used for maintenance purposes or in an emergency. Under normal usage, it should not be used for shutting down the humidifier as it switches off the unit prematurely and may damage the electrode boiler, invalidating the warranty.**

**Do not use the handles on the side of the casing to lift the unit.**

## Important notice to installers

Carefully read these instructions before installation and follow the processes explained by the manufacturer. These instructions are available in various other languages as well as English. Please contact Vapac for information.

Installation, commissioning, testing and maintenance of these products must only be carried out by suitably qualified and trained technicians and in full compliance with all applicable regulations and current best practices.

Check if the appliance as described on the packaging label is in accordance with the correct type and model as specified on the data plate and complies with your customer order. If a discrepancy is found, contact the distributor or manufacturer immediately.

The appliance must be powered with a voltage corresponding to the value shown on the rating plate.

These appliances must be installed in accordance with the rules in force and local regulations / legislation as appropriate plus all local building codes. Installers should satisfy themselves that the electrical installation and water and drainage pipework installation is carried out in accordance with all current legislation, Codes of Practice and recommendations.

The manufacturer cannot be held responsible from any matters arising from the revision to or introduction of new Laws, Standards, Directives, Codes of Practice or other recommendations.

Any reference made to Laws, Standards, Directives, Codes of Practice or other recommendations governing the application and installation of humidifiers and which may be referred to in Brochures, Specifications, Quotations, User Guides and Installation, Operation and Maintenance manuals is done so for information and guidance purposes only and should only be considered valid at the time of the publication.



**Improper installation, adjustment, alteration, service, or maintenance can cause property damage, injury, or death. Read the installation, operation and maintenance instructions thoroughly before installing or servicing this equipment.**



**Symbol IEC 60417-5597 (2002-10) is used on the unit to indicate that it operates with hot water vapour (steam). Take extra care when the humidifier is in use to avoid scalding and burns.**



**Please keep this manual in a safe place, where it can be immediately accessed. If the equipment is passed on to a new owner / operator, this manual must be passed on to them too. If this manual should be misplaced, please contact Vapac for a replacement.**

**G**

## Health and safety

---

Ensure that mounting points are suitable for the weight and loading of the product and if required, add suitable reinforcement to the anchoring points area.

Due consideration should be taken into account for workplace safety, risk assessments and waste disposal.

Any modification of the product may be hazardous and the manufacturer is not liable for any damage or injury caused by improper use.

Do not use this appliance if any control or electrical part has been immersed in or come into contact with water. Immediately call a qualified service technician to inspect the appliance and replace any control or electrical item that has been immersed in water.

This appliance is not intended for use by persons (including children) with reduced sensory or mental capabilities or lack of experience and knowledge, unless they have been given supervision or instruction concerning use of the appliance by a person responsible for their safety.

The appliance is not designed for use in hazardous atmospheres containing flammable vapours.

The Virtuoso VE steam humidifier is exclusively intended for air humidification within the specified operating conditions via a steam hose and distribution pipe, or in the case of the VE05 and VE09 models via an optional room distribution unit (RDU). Any other type of application, without the written consent of Vapac, will void the warranty.

This manual should be kept in a safe place for future reference.



**Shut off the water supply, drain the cylinder, isolate the unit electrically and allow the unit to cool down before carrying out any maintenance or other work on the humidifier.**

**Never leave water in the steam cylinder when the appliance is not in use; always drain it fully.**

**Do not carry out any work on the steam distribution system when the humidifier is in operation.**

**Do not store or use petrol or other flammable vapours and liquids in the vicinity of the appliance.**

**Improper installation, adjustment, alteration, service or maintenance can cause property damage, injury or death.**

**Read the installation, operation and maintenance instructions thoroughly before installing or servicing this equipment.**

**Installation, assembly, commissioning, service and maintenance procedures must be carried out only by suitably competent qualified persons.**

**Unauthorised modifications to the appliance, or departure from the manufacturer's guidance on intended use, or installation contrary to the manufacturer's recommendations may constitute a hazard and will void the warranty.**

**Use only factory authorised parts and spares when replacement is required.**

**In case of persistent problems, contact your distributor.**

This page is intentionally blank

# Technical data and dimensions

TD

Model	Max Steam Output (kg/hr)	Number of cylinders and steam outlets	Dia of Steam Outlets (mm)	Voltage (V)	Electrical Supply	Max Power Rating (kW)	FLC Range per Cylinder (A)	Max Fuse Rating Range (A)
VE05-1P	5	1	35	230	1 phase	3.78	19.5	32
VE09-1P	9	1	35	230	1 phase	6.76	35.5	63
VE09-3P	9	1	35	400	3 phase	6.79	20.5	32
VE18-3P	18	1	35	400	3 phase	13.48	23.5	32
VE30-3P	30	1	54	400	3 phase	22.38	39.0	50
VE45-3P	45	1	54	400	3 phase	33.85	59.0	80
VE60-3P	60	2	2 x 54	400	2 x 3 phase	2 x 44.81	2 x 36.5	2 x 50
VE90-3P	90	2	2 x 54	400	2 x 3 phase	2 x 67.50	2 x 55.0	2 x 80

It is possible for the units to be operated at differing voltages to those stated above; if required, this should be set by the service engineer at the time of commissioning. Full details are given in the cylinder electrical demand load tables following.

Model	Case Size	Dimensions			Dry Weight (kg)	Wet Weight (kg)	Connections	
		A (mm)	B (mm)	C (mm)			Water (BSP OD)	Drain (BSP OD)
VE05-1P	A	730	505	335	27.1	32.6	¾"	35
VE09-1P	A	730	505	335	27.1	34.1	¾"	35
VE09-3P	A	730	505	335	27.1	38.6	¾"	35
VE18-3P	A	730	505	335	27.1	38.6	¾"	35
VE30-3P	B	815	595	430	34.8	62.8	¾"	35
VE45-3P	B	815	595	430	34.8	62.8	¾"	35
VE60-3P	C	815	1050	430	56.1	112.1	2 x ¾"	35
VE90-3P	C	815	1050	430	56.1	112.1	2 x ¾"	35

Dry weight is the weight of the unit as delivered, wet weight is the weight of the unit in operation (i.e. filled with water)  
The water inlet pipe and the drain connection protrude 32mm and 19mm respectively below the unit casing.

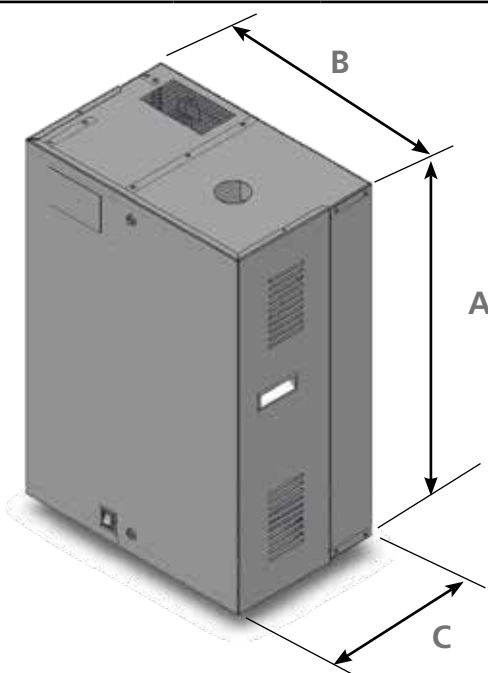

Model VE05-1P, VE09-1P, VE09-3P, VE18-3P, VE30-3P and VE45-3P

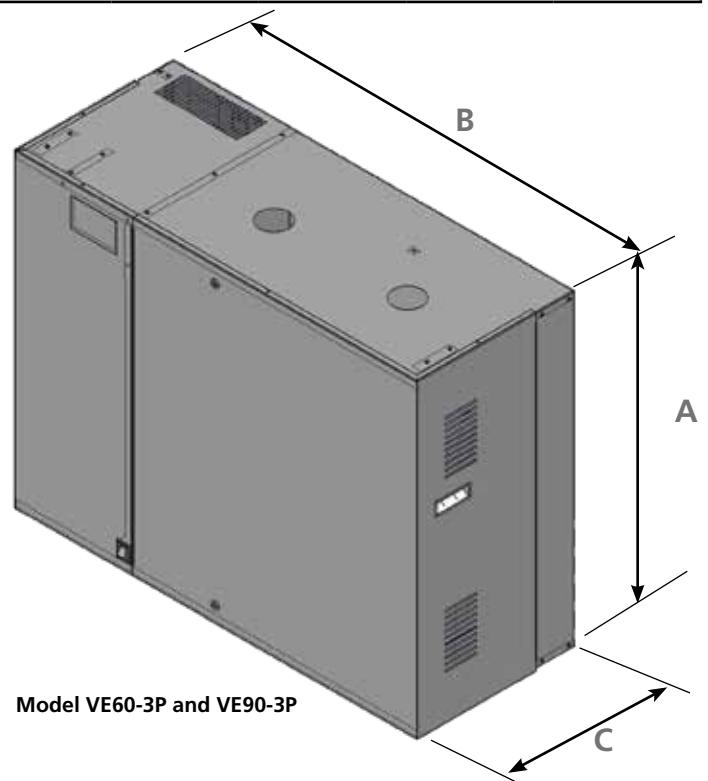

Model VE60-3P and VE90-3P



# Clearances

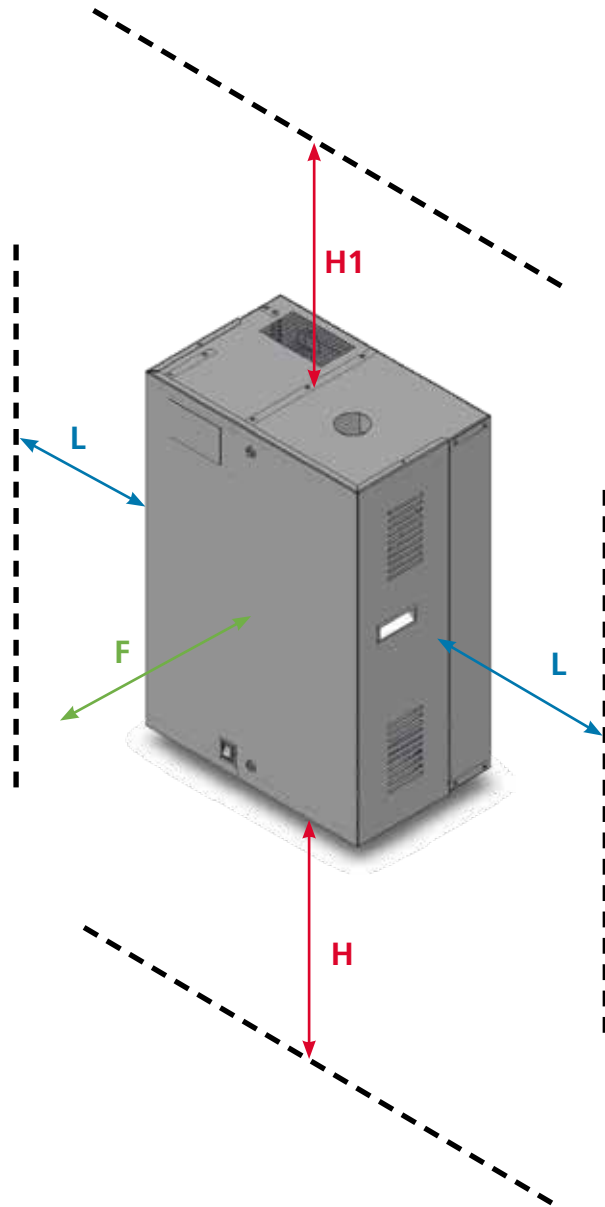

Model	L mm	H mm	H1 mm	F mm
VE05-1P	250	1000	500	1000
VE09-1P/-3P	250	1000	500	1000
VE18-3P	250	1000	500	1000
VE30-3P	250	1000	500	1000
VE45-3P	250	1000	500	1000
VE60-3P	250	1000	500	1000
VE90-3P	250	1000	500	1000
Minimum clearances around the unit Allow a minimum of 1000mm front access (F)				

# Installation

## Unpacking / preparation



**Read this booklet and become familiar with the installation requirements of your unit.**

**The unit MUST be stored and transported in its original packaging until installation time.**

**Prior to installation, the unit must be stored in a protected area with temperature / humidity limits of 5°C to 35°C / 10 to 75% rh.**

**Prior to packing and shipping, the unit was test operated and inspected at the factory and left in full operating condition.**

Lifting or handling MUST be carried out by trained and qualified personnel. Ensure that the lifting operation has been properly planned, assessed for risk and that the equipment has been checked by a competent Health & Safety representative and effective control measures are in place.

It is the customer's responsibility to ensure that the operators are trained in handling heavy goods and to enforce the relevant lifting regulations. The humidifier MUST be handled and lifted with care at all times. The unit MUST be stored and transported in its original packaging until installation time.

The steam humidifier is shipped inside a cardboard outer with a separate cardboard base all mounted on a wooden pallet and secured with banding. All packaging materials with the exception of the banding are recyclable.

The steam humidifier package may be transported / moved using a forklift from the underside of the pallet. Exercise caution before lifting to ensure that the load is balanced.

If the packaging or unit has incurred damage in shipment, document the damage with the transport company and contact your dealer or customer services.

After removing the cardboard outer, leave the appliance sitting on the cardboard base and the wooden pallet until just before siting to prevent damage to the base of the unit and the bottom connections.

The front flap of the cardboard base folds down (and also the right hand side of the base for the double cylinder units VE60-3P and VE90-3P) to allow the front panel(s) of the unit to be removed without removing the unit from the cardboard base.

Check if the local distribution conditions of electricity supply, type of water supply and pressure are compatible with the data plate.

The appliance must be installed in accordance with the current rules in force and any local or national regulations.

The requirements of the "Local Building Standards office" and the premises "Insurance undertaking" must also be observed.

Before commencing installation, ensure all necessary supplies, tools and manpower are available.

The unpacking process can be summarised as follows:-

- Cut away the banding.
- Remove the cardboard outer.
- Remove the manual and retain for use.
- Fold down the front flap of the cardboard base.
- Remove the front cover of the unit.

Figures 1a to 1d opposite show the process.



**Fig 1a - Unit on pallet with cardboard outer secured by banding**



**Fig 1b - Unit on pallet, banding removed, lifting cardboard outer**



**Fig 1c - Unit on pallet and cardboard base with cardboard outer removed**



**Fig 1d - Unit on pallet with cardboard outer removed and front flap of base folded down, front panel removed**

## List of accessories supplied

The following accessories are supplied with the Virtuoso VE Steam Humidifier:

- Bracket for wall mounting the humidifier (supplied bolted to the back of the unit).
- 2 adjustable hose clips per steam outlet for the connection of steam hose.
- Water supply inlet feed flexible pipe per water supply connection.
- Installation manual (this document).
- Printed template to assist in the location of the unit mounting bracket.



Front panels have a simple blade lock that may be opened using a suitably sized flat blade screwdriver; no keys are required or provided.

## Humidifier location



**The mechanical and electrical installation must comply with all local and national codes and regulations in place at the time of installation.**

**The appliance is designed for indoor installation only.**

For best results, the humidifier should be installed with the following rules in mind:

### Installation Do's:-

- Do ensure that the humidifier is mounted in an accessible location that permits easy inspection and servicing of the humidifier. Minimum clearances detailed previously must be maintained.
- Do ensure that the floor beneath the humidifier is waterproof so as to withstand any water spillage or leakage during servicing or if a problem occurs.
- Do mount the unit as close to the steam distribution pipe(s) as possible. The total flexible hose steam line **MUST NOT** exceed 5 metres in length.
- Do mount the unit at a convenient height to read and use the touch screen display panel.
- Do ensure the location of the unit is well ventilated such that the ambient temperature does not exceed 40°C or falls below 5°C.
- Do be aware that high humidity levels may encourage the growth of biological organisms in the environment.
- Do use the supplied printed template to mark the mounting hole positions.
- Do be aware of the unit weight. All applicable handling and lifting safe practises must be followed.
- Do remove the cylinder if necessary to access the mounting holes in the back of the steam section.
- Do use suitably sized wall bolts or equivalent to mount the unit.

### Installation Don'ts

- Don't use the handles on the side of the casing to lift the unit.
- Don't install the humidifier where failure of the appliance could cause damage to other equipment or the building structure.
- Don't mount the unit close to sources of strong electro-magnetic emissions e.g. transformers, etc.
- Don't mount the unit in an unventilated enclosure.
- Don't mount the unit in a location requiring ladder access.
- Don't mount the unit within a false ceiling or other location where a malfunction would cause damage e.g. a water leak.
- Don't mount the unit where temperature and humidity conditions can cause condensation on electrical components e.g. a cold room.
- Don't mount the unit in a location where the sound of water flow in a pipe would be unacceptable e.g. a library, private apartment, etc.

## Mounting the humidifier



**Do not locate the humidifier where it may be exposed to water or where the ambient temperature exceeds 40°C or falls below 5°C.**

**Ensure that the structural elements which will be used to support the humidifier are adequate to carry the wet weight of the appliance and its ancillary components. Unit dry and wet weights are given in the technical data section previously.**

**Sufficient space must be provided around the humidifier for access, servicing and safety (see clearances on page 11 for details).**

**Do not use the handles on the side of the humidifier cabinet to lift the unit.**

**Ensure that the humidifier is installed in a level plane.**

**The humidifier is designed for wall mounting using the bracket provided with the appliance.**

**Do not add additional weight to the mounted humidifier.**

The humidifier is delivered in a packaging carton on a cardboard base and wooden pallet as discussed in the "Unpacking / Preparation" section earlier; leave the unit on the base and pallet until you are ready to hang it. If the bottom of the unit is not protected or supported prior to installation, damage can occur.

To mount the humidifier:-

1. Position the supplied bracket on the wall, using the printed template supplied with the unit.
2. Drill suitably sized wall bolts into the slotted holes of the bracket to secure the bracket to the wall (two for single cylinder units and three for double cylinder units).
3. Remove the front panel from the humidifier.
4. Secure the humidifier to the bracket by sliding the open slots on the back of the unit onto the tab inserts located on the bracket.
5. From inside the humidifier, verify that the holes in the unit back wall are aligned with those in the tabs on the bracket.
6. From inside the humidifier, use suitably sized screws via the holes in the tabs on the bracket in order to secure the humidifier to the bracket.
7. For extra rigidity, the unit can be screwed to the wall via screw hole(s) towards the bottom of the unit (one for Case A units and two for Case B and C units).
8. Slide front panel onto unit and close locks.

Please refer to the separate installation instructions for details of installing and maintaining the Room Distribution Unit RDU.

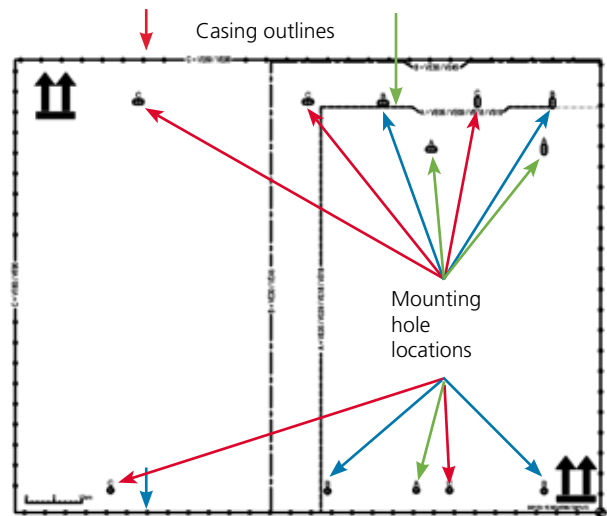

Fig 2a - Installation template

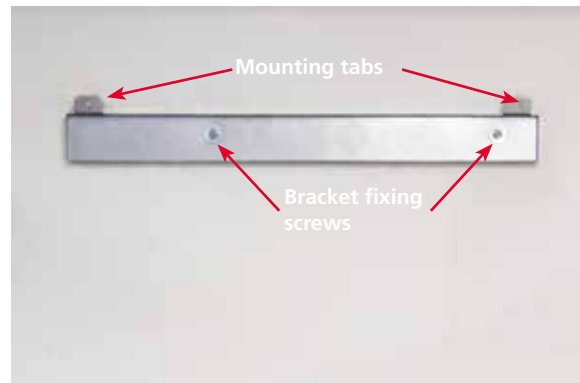

Fig 2b - Bracket mounted on wall



Fig 2c - Lifting the unit, front panel removed



**Fig 2d - Hanging the unit onto the tab inserts on the bracket**



**Fig 2g - Unit mounted on wall, no front panel**



**Fig 2e - Close up showing bracket tab and screw holes inside unit**



**Fig 2h - Sliding front panel on to unit**

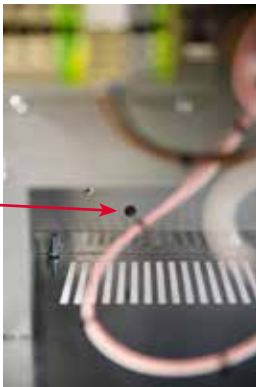

Hole at bottom of unit for additional screw fixing

**Fig 2f - Close up of screw holes at bottom of unit**



**Fig 2j - Humidifier mounted with front panel locked in place**

## Cold water supply and drainage

¾" water supply pipe with stop valve and strainer (by others)  
1.5 to 8.0 bar

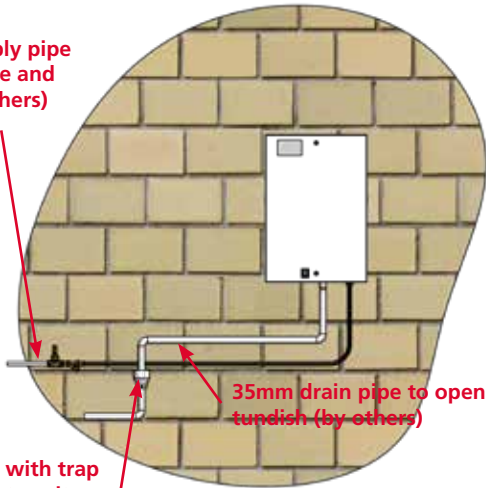

35mm drain pipe to open tundish (by others)

Open tundish with trap to drain sized to suit drain flow (by others)

Single cylinder units VE05, 09, 18, 30, 45

2 off ¾" water supply pipe with stop valve and strainer (by others)  
1.5 to 8.0 bar

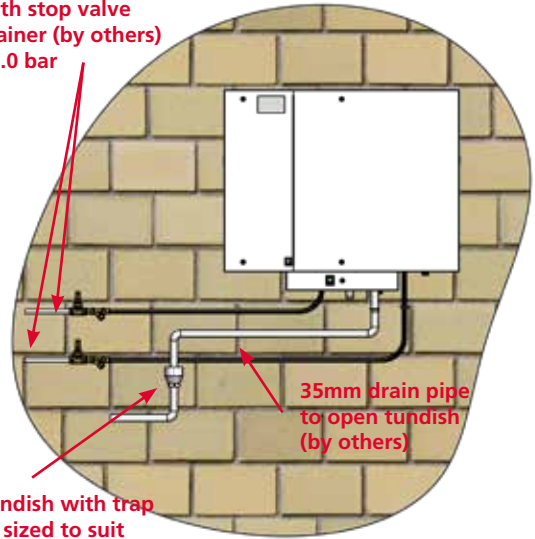

35mm drain pipe to open tundish (by others)

Open tundish with trap to drain sized to suit drain flow (by others)

Double cylinder units VE60, 90

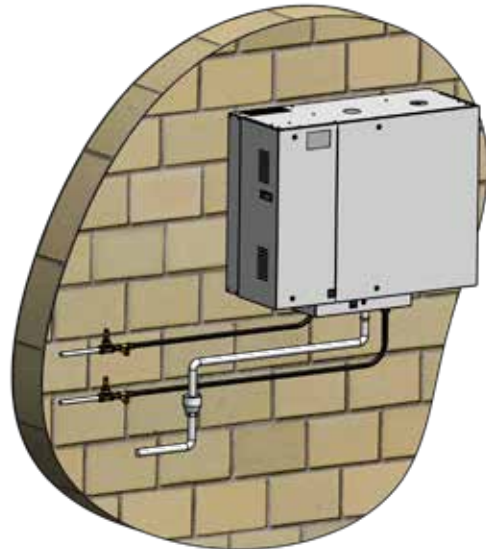
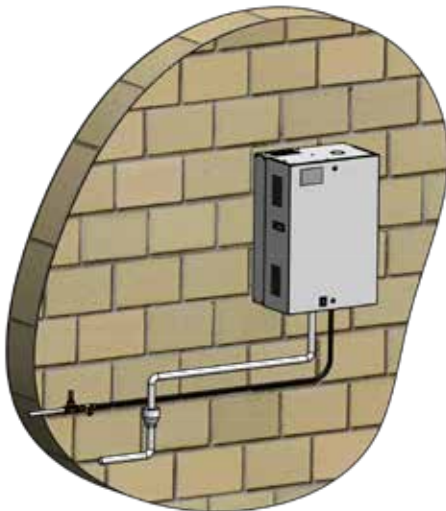

Water and drain connection detail

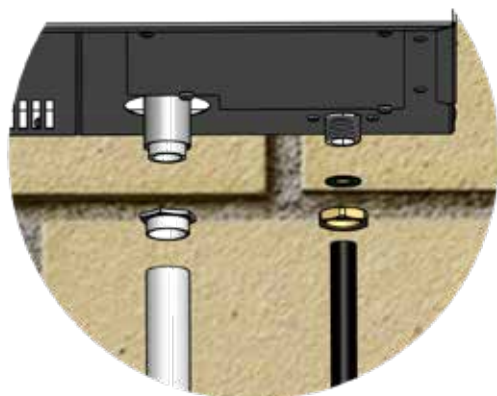

Note:

The diagrams given on this page are indicative only and should be read in conjunction with the following sections of this installation manual:-

- "Mounting the Humidifier"
- "Cold Water Supply"
- "Water Drain Connections"

The humidifier has been designed for internal use only.

**Fig 3 - Typical water and drain connections**

## Cold water supply



The unit has been designed for use with a permanent cold water supply. The cold water pipework must conform to local and national codes and regulations. The installation must be carried out by suitably qualified personnel.

The unit has been designed to withstand the water pressure expected in normal use when connected to the cold water supply (limits shown in table 4 below). This includes the supplied inlet water flexible hose(s) if used.

[Fig 3 on page 15](#) previously shows typical water supply connections for both single and double cylinder units.

The table on page 30 details how to select the correct cylinder for the model of unit and the water conductivity range.

Virtuoso VE electrode boiler steam humidifiers are capable of operating with a wide range of "raw mains" quality water supplies. The water supply should be within the following limits:-

Water Supply Condition	Limits
Hardness	50 - 500 ppm
Conductivity	80 - 1000 $\mu$ S/cm
pH	7.3 - 8.0
Silica	0 - 8 ideal Above 8 (see note below)
Pressure	1.5 - 8.0 bar 150000 - 800000 pascals
Temperature	1 - 30°C

**Table 1a - Water supply conditions**

Note if the silica content of the supply water is above 8, a stainless steel electrode cylinder must be used in the humidifier. If the silica content is above 12, the life of the cylinder will be significantly reduced. Additionally, if stainless steel electrodes are used, the chlorine level must not exceed 170ppm.

Model	Water supply rate (l/min)
VE05-1P	1.20
VE09-1P/-3P	1.20
VE18-3P	1.20
VE30-3P	2.50
VE45-3P	2.50
VE60-3P	5.00
VE90-3P	5.00

**Table 1b - Water supply rates**

Water supply do's

- Do install a stop valve / shut off valve, double check valve / backflow prevention device and a strainer close to the unit.
- It is recommended that a water hammer arrestor is installed in the cold water supply line to absorb hydraulic shock and minimise water hammer when the humidifier fill valve closes. Water hammer is a phenomenon that can occur in any piping system where valves are used to control the flow of liquids.
- Do provide a water supply with sufficient pressure and the correct pipe size to ensure that an adequate flow rate is provided to all units connected to the system.
- Do ensure the water supply pipework is fastened with suitable bracketry.
- Do ensure metal cold water supply pipework is earthed electrically close to the unit.

Water supply don'ts

- Don't use a wrench or similar tool to tighten the water supply connection. The nylon nut and rubber washer provided should only require tightening by hand to effect a seal.
- Don't use additives such as corrosion inhibitors and disinfectants, since these additives may endanger health and affect proper operation.
- Don't add salt or solutions to the supply water.



## Water drain connections



**The water drainage pipework must confirm to local and national codes and regulations. The installation must be carried out by suitably qualified personnel.**

**Fig 3 on page 15 previously shows typical water drain connections.**

**The drain flow rate for all single cylinder models is 17 litres per minute.**

**Double cylinder models have two drain pumps each producing 17 litres per minute. These drain pumps can operate concurrently.**

Drain connection do's:-

- Do use copper or plastic pipe rated for a temperature of 110°C.
- Do design the pipework to discharge drain water from the unit into a trapped and vented drain where flash steam rising from the drain line vent will not pose a problem to the humidifier or other equipment. Figure 3 previously illustrates a suitable drain pipeline layout.
- Do provide an adequate fall for the drain pipework to allow the free flow of water drained from the unit.
- Do ensure that the drain line is correctly sized especially if more than one humidifier is draining into the same pipeline.
- Do ensure metal drain pipework is earthed electrically close to the unit.
- The minimum drain pipe gradient must be at least 6.5mm per 300mm.



## Mounting the steam pipe(s)

Steam pipes should be positioned as shown in [figures 4-8 following](#), allowing a minimum rate of fall back to the unit of 12% to allow the free flow of condensate back to the humidifier. If the above fall is not possible, then condensate separators must be fitted.

The position of the steam pipe in a duct system relative to other items such as bends, filters, heat exchangers, etc., is critical. The steam pipe must not be located closer to such items than the steam absorption distance. Further information and design guidance on absorption distances is given in [figures 8 and 9 following](#).

### Steam pipe do's

- Do obtain the project / design engineers instructions and drawings for the chosen location of the steam pipe including the position relative to the top and bottom of the duct (or sides if the airflow is vertical).
- Do check if an alternative slope has been specified for the steam pipe.
- Do use a bracket / lug on 54mm dia. steam pipes for extra support.
- Do use Vapac steam hose or well insulated copper pipe.
- Do keep the steam hose / pipe as short as possible (a maximum length of 4 metres is recommended; use less than 2 metres for maximum efficiency).
- Do use the full height available between the unit and steam pipe to provide the maximum slope (minimum of 12-20%) for condensate to drain back to the steam cylinder (or down to a condensate separator). Always provide a continuous slope.
- Do provide adequate support to prevent sagging of the steam hose by either fitting pipe clips every 300-500mm or by supporting straight lengths on cable trays or in heat resistant plastic pipe.
- Do ensure radius hose bends are fully supported to prevent kinks developing when in service.

- Do add extra insulation to steam hose / pipe for longer runs (2m - 5m) and in cold ambient conditions so as to avoid excess condensate and a reduction in delivered output.
- Do have a vertical rise off the unit of at least 300mm.

### Steam pipe don'ts

- Don't allow steam hose to develop kinks or sags as this will cause condensate pockets.
- Don't include horizontal runs or 90° elbows in the steam line.
- Don't install a stop valve (e.g. a manual isolating valve, a solenoid valve, etc.) in the steam line.

Model	VE 05	VE 09	VE 18	VE 30	VE 45	VE 60	VE 90
35mm dia pipe	1	1	1	-	-	-	-
54mm dia pipe	-	-	-	1	1	2	2
Duct pressure	+ 2000 / - 600 Pa						

**Table 2 - Steam pipe requirement**

35mm Dia Pipe	
Duct Width B (mm)	In Duct Length L (mm)
320-470	300
470-620	450
620-770	600
770-920	750
920-1070	900
1070-1200	1050

54mm Dia Pipe	
Duct Width B (mm)	In Duct Length L (mm)
700-950	650
950-1450	900
1450+	1400

**Table 3 - Steam pipe selection**



# Guide to positioning steam pipes

The information provided in this section is offered as a guide only. Vapac accepts no responsibility for the positioning of any pipes in a system. This remains the responsibility of the Design Engineer.

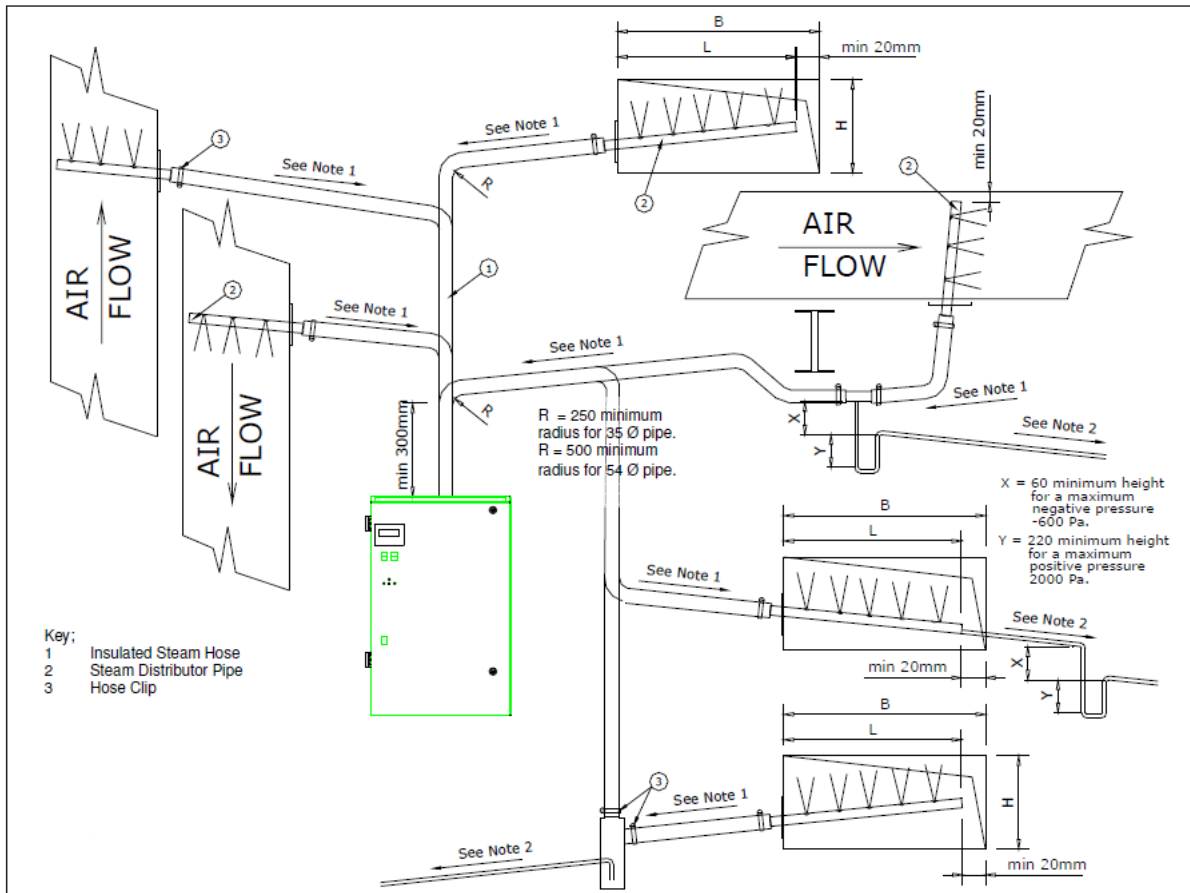

**Fig 5 - steam pipe location**

Notes:

1. Keep the steam hose / pipe as short as possible. A maximum length of 4 metres is recommended; use less than 2 metres for maximum efficiency.
2. Steam pipe to have a minimum slope from the horizontal of 7° or 12% to allow the condensate to drain back to the cylinder or trap. NO HORIZONTAL RUNS. NO 90° ELBOWS.
3. Water condensate tube to slope at 10° or 18% from the horizontal for condensate to drain back to drain point.
4. Steam pipes which are mounted horizontally must discharge vertically upward.
5. Vertically mounted Steam pipes must discharge horizontally facing upstream airflow.
6. If the total pressure within a duct air flow exceeds 2000 Pa and the static is below 2000 Pa then the probe may face horizontally at right angles to the air stream.
7. Care should be taken to support steam hose sufficiently such that no kinks are formed which would flood with condensate causing the bore of the tube to become constricted, leading to excessive pressure in the steam lines.

Standard steam distribution pipes are manufactured such that any condensate is drained back towards the Vapac steam cylinder.

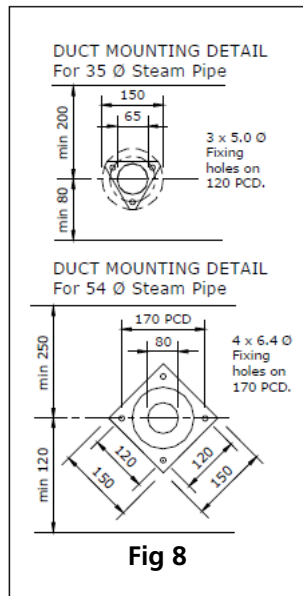
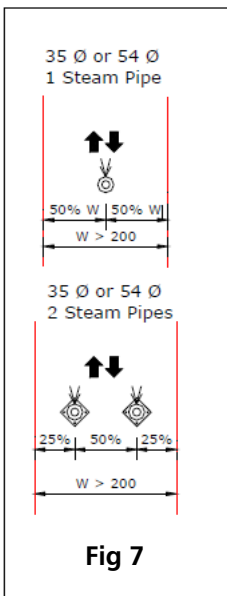
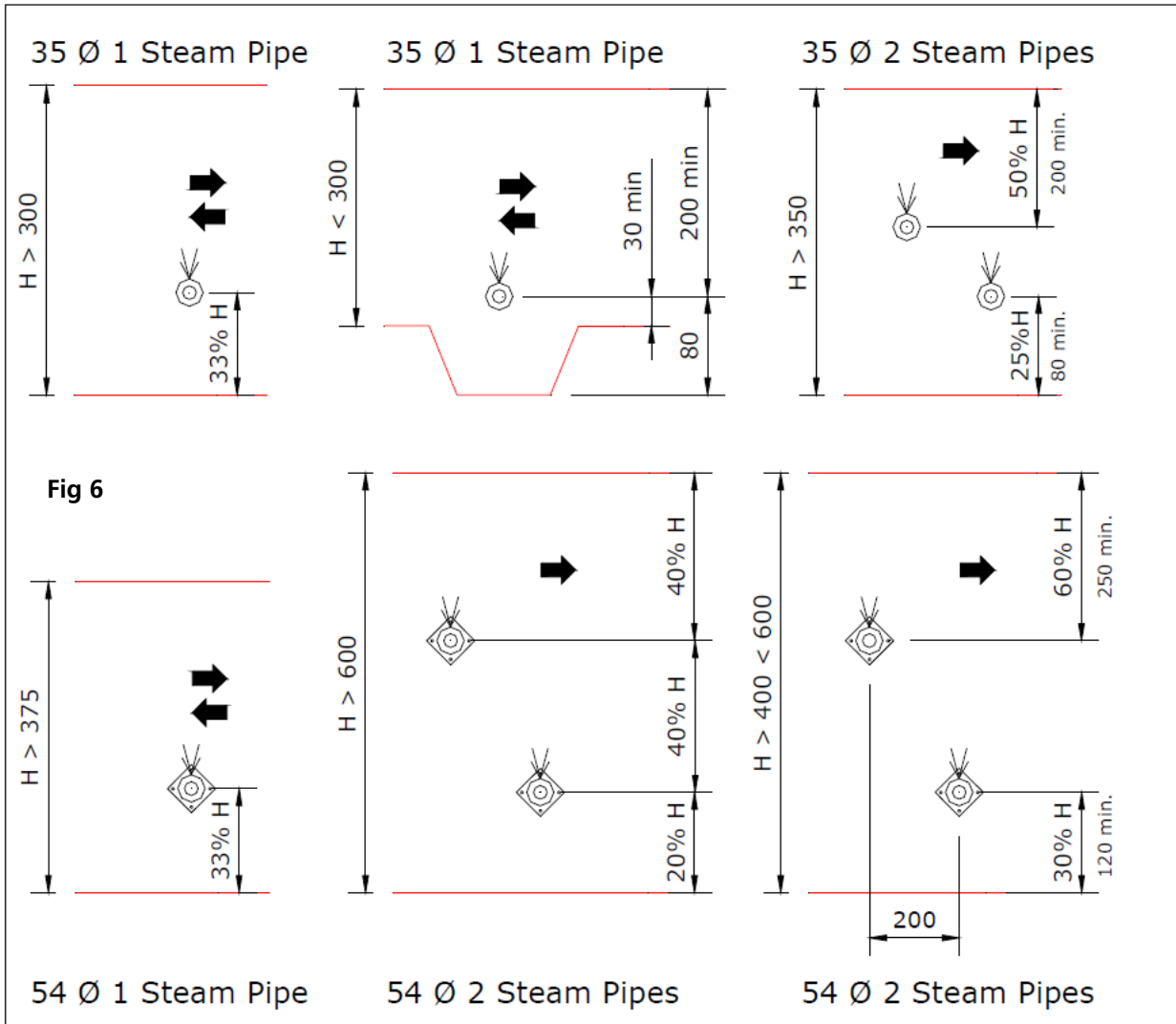

Figure 5 (page 22) shows the versatility of the steam pipe / steam hose steam delivery system. It also indicates where and how condensate traps / condensate separators should be used. If the steam pipe slopes such that the steam connection is lower than the far end of the pipe, this indicates that a reverse slope steam pipe is required. This is fitted with a drain point to allow condensate to be taken away to a convenient drain.

Figure 6 (this page) shows recommendations on how to space steam pipes in a horizontal duct.

Figure 7 (this page) shows recommendations on how to space steam pipes in a vertical duct

Figure 8 (this page) shows duct mounting details for 35 and 54 Ø steam pipes

Figure 9 (page 24) provides information for the calculation of the humidifier absorption distance complete with an example

Figure 10 (page 24) shows the relative position for siting the steam pipe in ductwork



**The details given in this section are specific to Vapac steam pipes. Other steam pipes may differ. In that instance, refer to the original manufacturers instructions for details.**

**Air temperature at the steam pipe**

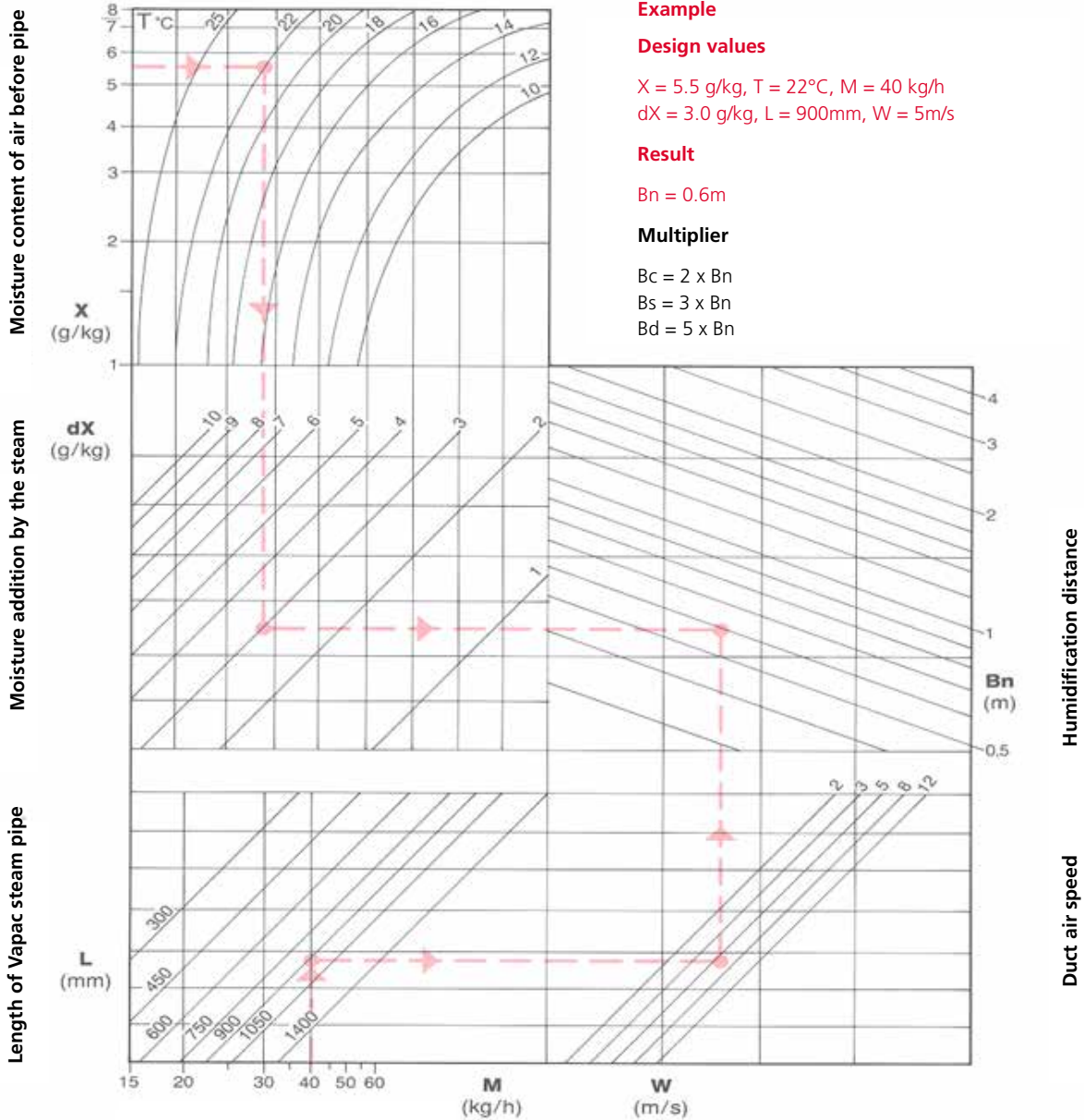

**Example**

**Design values**

X = 5.5 g/kg, T = 22°C, M = 40 kg/h  
 dX = 3.0 g/kg, L = 900mm, W = 5m/s

**Result**

Bn = 0.6m

**Multiplier**

Bc = 2 x Bn

Bs = 3 x Bn

Bd = 5 x Bn

**Steam quantity per steam pipe**

**Humidification distance**

- Bn = normal airflow
- Bc = before a filter
- Bs = before an absolute filter
- Bd = before a sensor

**Fig 9 - humidification distance chart**

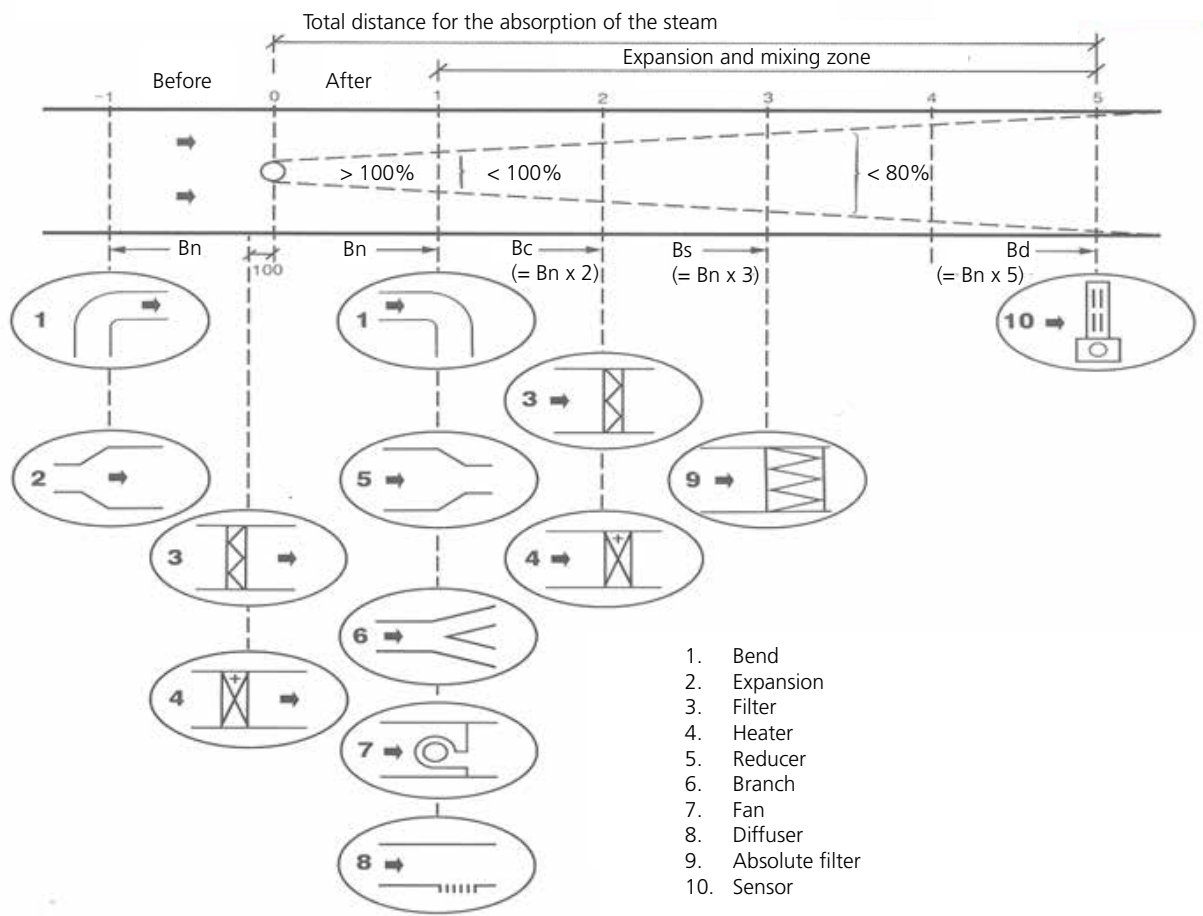

**Fig 10 - relative position in duct**

## Electrical supply and connections



The electrical installation **MUST BE** carried out by an appropriately qualified person in accordance with the current Rules and Regulations in force.

This appliance must be earthed via a PE earth connection connected to the units earth terminal.

The appliance **MUST NOT** be operated from a DC supply.

Twin cylinder units have terminals for the connection of two separate power supply input circuits (power supply A and power supply B) to allow individual circuit protection of each steam cylinder. For safety reasons, both cylinder power supplies should be isolated when accessing the unit.



Fig 11 - incoming power terminals

A transformer is located within the control section to provide a 24V AC output for control purposes. The transformer has input tapplings for 200V, 230V, 380V, 415V and 440V. Wire TX **MUST BE** connected to the input tapping corresponding to the main incoming supply voltage. Under normal circumstances Wire TX is connected to the correct input tapping at the time of manufacture.

The transformer **MUST NOT** be used to power other equipment. This will invalidate the warranty.

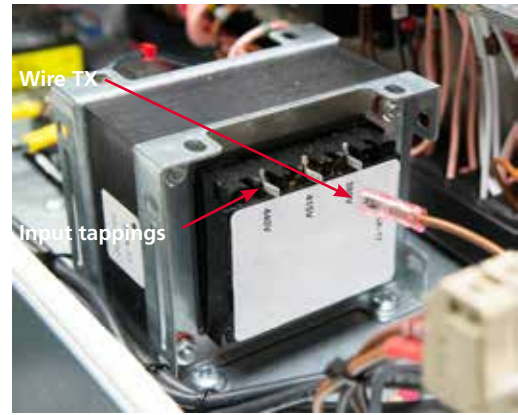

Fig 12 - transformer and wire TX

Check that the electrical specification is in accordance with the specified data on the humidifier. Ensure that the cross-sectional area and length of the supply cables is appropriate for the current supplied.

All electrical connections must be made in the humidifier control compartment (see the exploded views in the [technical data section on pages 8 and 9](#)). Connections must be in accordance with the terminal markings and the wiring diagrams contained in this manual.

The supply line to the humidifier should include a mains switch / isolator adjacent to the appliance.

Check that the humidifier is earthed and that an earth leakage test is carried out.

Ensure that all cables and installers wiring are appropriately fixed.

Cable glands **MUST** be used to ensure cables are held securely at the entry position. All Virtuoso cabinets are equipped with knock out gland opening plates which the installing electrician should remove and trim for the required cable gland size.



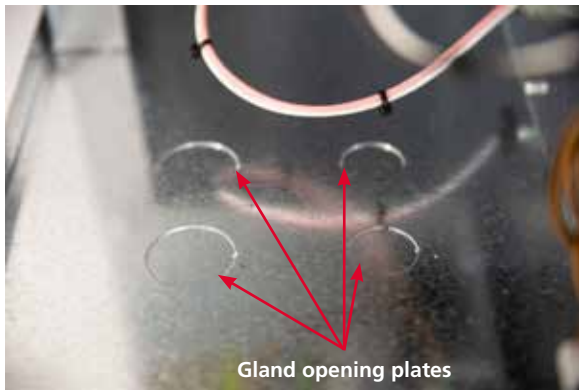

**Fig 13 - knock out gland plates**

### Control input connections

Virtuoso humidifiers have been designed for control by the following methods:-

- On / off demand signal by others - 3V is provided at the controller (terminals 57 and 59)
- External demand signal 0-10V DC (e.g. BMS) by others (terminal 58 [+V DC] and terminal 59 [-V DC])
- Temperature / humidity sensor by others (terminals HOV, H24V, 60 [TH1], 61 [TH2] and 62 [OP1])



**Only one of the control inputs detailed above can be used at any time.**

Use screened cable for all control and safety circuit connections to minimise risk of electrical interference.

### Safety circuit / emergency shut down

A pair of volt free terminals (13 and 14) have been provided to allow connection of an emergency shut down button or a fire alarm interlock / fire shut down facility. Other control interlocks such as a fan interlock, airflow switch, high limit hygostat or any combination of them may also be connected in series to these terminals. These terminals should be looped out if not used. It should be noted that breaking of these terminals will prevent all operation of the unit.



### Volt free outputs

The unit has connections for the following volt free outputs:-

- T63 and T64 Alarm signal (close on alarm)
- T65 and T66 Run signal (close on run)

### Wiring diagrams

The following wiring diagrams are provided at the rear of this manual.

Drawing No	Model
D301585 (3 shts)	Single phase models VE05-1P, VE09-1P
D301586 (3 shts)	Three phase single cylinder models VE09-3P, VE18-3P, VE30-3P, VE45-3P
D301587 (3 shts)	Three phase double cylinder models VE60-3P, VE90-3P

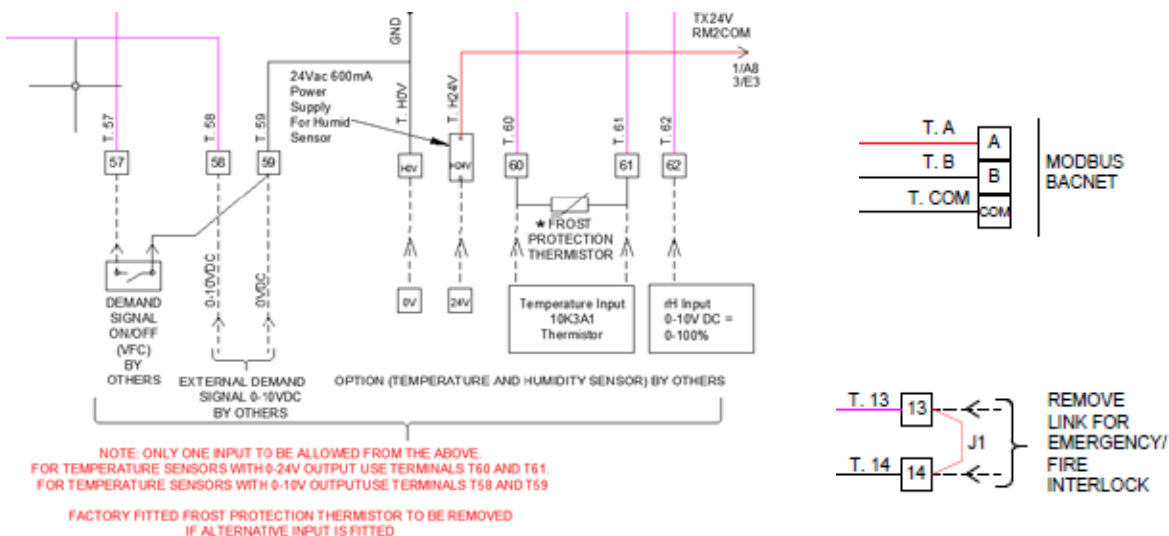

**Fig 14 - Control input and interlock connections**

## Touch screen display panel

The touch screen display panel allows access to the following "on-screen" modes:-

- Initial Startup Mode
- Normal Operating Mode
- Commissioning Mode via PIN (6787)
- Service Mode via PIN (for service engineer use only)
- Advanced Mode via PIN (for service engineer use only)

### Initial Startup Mode

#### 1. Starting Up Please Wait



**Starting Up Please Wait.**



When power is initially applied to the unit, the "Starting Up Please Wait..." screen will be displayed for up to 3 minutes whilst the system carries out its start up checks.

Once the system has completed its start up checks, the unit will enter Normal Operating Mode. If the unit has not previously been commissioned, the procedures described in "Commissioning Mode" on page 28 must be carried out for the unit to enter normal operating mode.

#### 2. Setting System Time and Date

The system has an in-built time clock which was set at the time of manufacture. To change the the time / date:-

- touch the set-up button (top right hand side of the screen)
- the mode selection screen will appear
- touch the "language / time" button
- the select language / set clock screen will appear.

- to set the time, use the + and - buttons above the displayed hours : minutes : seconds
- to set the date, use the + and - buttons above the displayed date : month : year
- Select the tick.



The system will then enter normal operating mode. Note that the language should not be changed.

A back-up battery (type CR1220) is fitted to the screen display board to prevent the set date and time being lost in the event of a power failure or the electrical supply to the unit being isolated. The battery location is shown below.



Note that the Home button will not work in this mode.

### Normal Operating Mode

Once the initial setup has been completed, the unit will switch to normal operating mode and the touch screen will show the operational status of the unit: STANDBY, STEAMING, FILLING, DRAINING, SERVICE DUE, CAUTION ALARM and CRITICAL ALARM (as shown in the following screenshots and described in the "Operation" section on page 37 following).

### 1. Standby mode

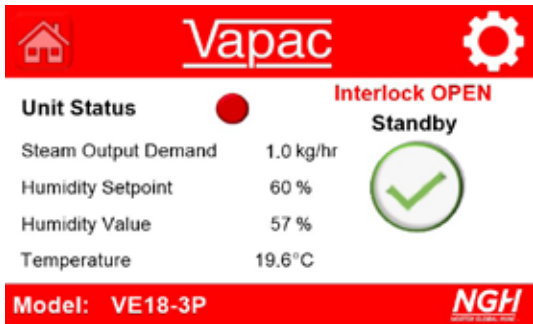

- In standby mode, the unit is operating and awaiting a call for humidification. The display will show "interlock open" until the unit enters steaming mode (i.e. there is no demand for steam from an external enable signal). Note that the temperature will be displayed only if a suitable temperature sensor is connected to the humidifier.

### 2. Steaming mode

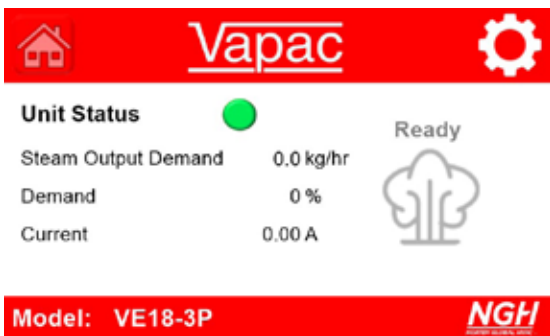

- In steaming mode, the unit is operating normally and creating steam.

### 3. Filling mode

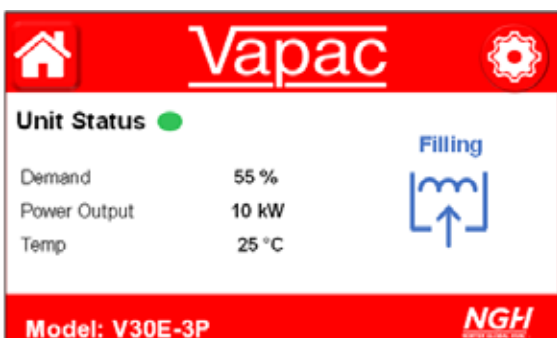

- In filling mode, the unit is operating normally and the cylinder is being filled

### 4. Draining mode

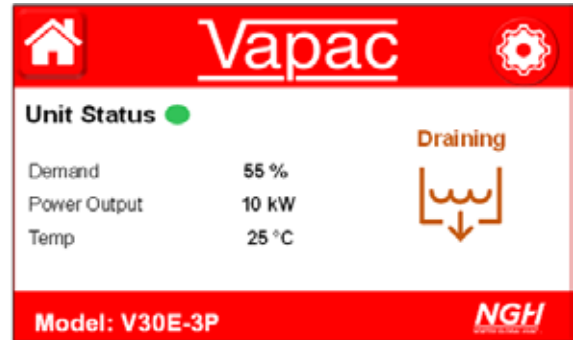

- In draining mode, the unit is operating normally and the cylinder is being drained.

### 5. Caution Alarm

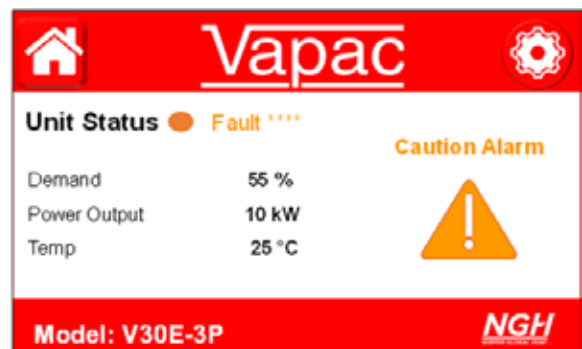

- In the event of a caution alarm, the above screen will show then alternate with the applicable operating screen at 5 second intervals. In this instance a fault code will also be provided:-

1 - Cylinder 1 Feeding for longer than MaxFeedTime

2 - Cylinder 1 Low output fault 1

4 - Cylinder 1 Low output fault 2

8 - Cylinder 1 Draining for longer than TotalDrainTime

16 - Cylinder 1 Overcurrent fault > 112% of Max Operating Current

32 - Cylinder 1 High Overcurrent fault > 115% of Max Operating Current

The following fault codes apply to two cylinder units only:-

256 - Cylinder 2 Feeding for longer than MaxFeedTime

512 - Cylinder 2 Low output fault 1

1024 - Cylinder 2 Low output fault 2

2048 - Cylinder 2 Draining for longer than TotalDrainTime

4092 - Cylinder 2 Overcurrent fault > 112% of Max Operating Current

8196 - Cylinder 2 High Overcurrent fault > 115% of Max Operating Current

Note that any combination of faults can be displayed with a caution alarm, the fault code displayed being the sum of the fault codes; e.g. 1 feed valve fault + 2 Cylinder 1 low output fault would display fault code 3

## 6. Double cylinder units

For the VE60 and VE90 double cylinder units the screen display will show the normal operating condition of both cylinders, as per the following two screenshots.

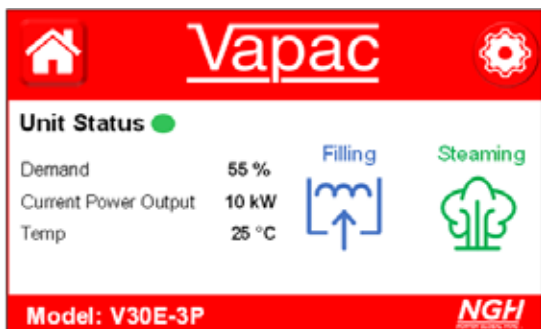

- The above screen shows one cylinder filling and one steaming.

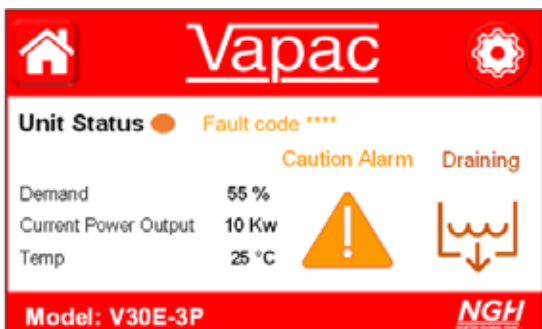

- The above screen shows one cylinder under caution alarm and one draining. As previously described in 5. Caution Alarm, a fault code will be given on the screen in the event of a caution alarm.

## 7. Mode selection

If the setup button is touched during normal operation (or any mode other than initial setup), the mode selection screen will appear

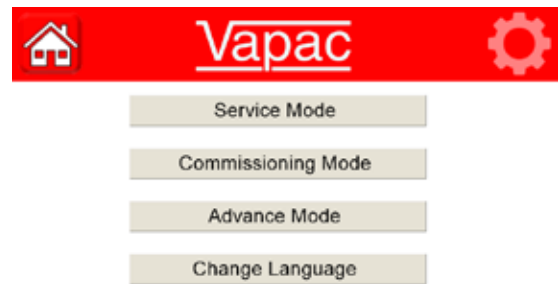

Model: VE30-3P

NGH

- Touching the Commissioning Mode button will go to a PIN entry screen. Enter 6787 then touch the tick to go to the [commissioning mode screen](#).
- The [Service Mode](#) and [Advance Mode](#) buttons are PIN protected and for use by the Service Engineer only.
- Touching the Language / Time button will go to the [Select Language page](#) described below.
- Touching the Home button will revert to the applicable [normal operating screen](#).

## 8. Select language / change time



Model: VE09-3P

NGH

- Touch the flag for the required language
- The system time and date can be changed in the manner described previously
- Touch the tick to save the required selection

## Commissioning Mode

If commissioning mode is selected from the mode selection screen by entering the PIN 6787, the touch screen will display various parameters that can be viewed and changed as shown below.

## 1. Commissioning Mode Page 1



- The input type notifies the control software what control input it needs to look for. When the adjacent Change button is pressed, the Select Input Type screen opens as below to select the required input.

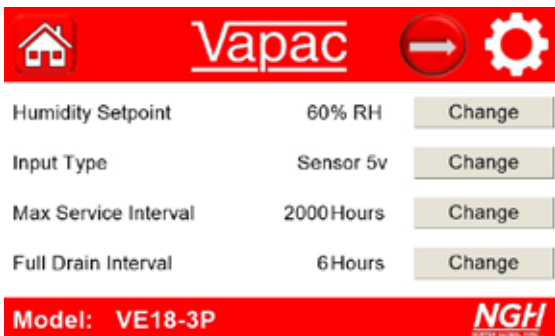

- The Select Input Type Screen allows the type of control for the humidifier to be set. One of the options MUST be selected for the unit to operate. Ensure that the associated control input method is provided (see page 23 for details). There are 6 different options available:-

a) External demand signal 0-10V should be selected if you wish to control the unit via a 0-10V external demand signal from, for example, a BMS. Use terminals T58 and T59 in this instance.

b) Humidity Sensor 0-5V should be selected if you wish to control the unit via a 0-5V humidistat. Use terminals T58 and T59.

c) Humidity Sensor 0-10V should be selected if you wish to control the unit via a 0-10V humidistat. Use terminal T62. This is the default setting.

d) Humidity+Temperature Sensor 0-10V should be selected if you wish to control the unit via a 0-10V combined temperature and humidity sensor. Use terminals T60 and T61 (temperature and T62 (humidity)).

e) On/Off Input should be selected if you wish to control the unit via a simple on/off control. Use terminals T57 and T59 (3V is provided from the controller).

f) Modbus should be selected if you wish to control the unit via a Modbus interface

When a 0-5V or 0-10V humidity sensor or a 0-10V combined temperature and humidity sensor is selected, the humidity setpoint will be displayed. The required relative humidity percentage (%RH) can be changed via the change button. The default value for this is 100%. It should be noted that this will be "greyed out" for all other types of input control device.

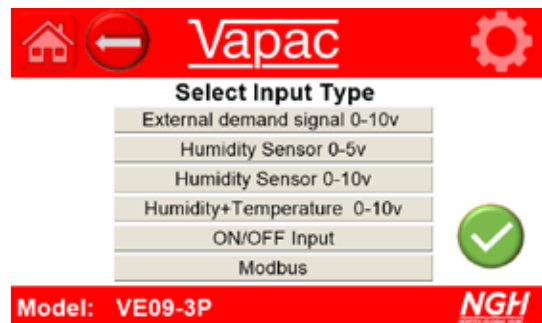

- The set maximum service interval will be displayed. This is the amount of hours that will pass before "Service Required" will be displayed on the screen. This can be increased or decreased to suit the specific site requirements. The default setting for this is 2000 hours.
- The set full drain interval will be displayed. A full drain interval is the time (in hours) before the unit automatically conducts a full cylinder drain (90 second drain), before beginning a new feed / boil cycle. This can be increased or decreased to suit the specific site requirements. The range is 0-192 hours, the default is 6 hours and the function can be deactivated by setting to 0.

## 2. Commissioning Mode Page 2

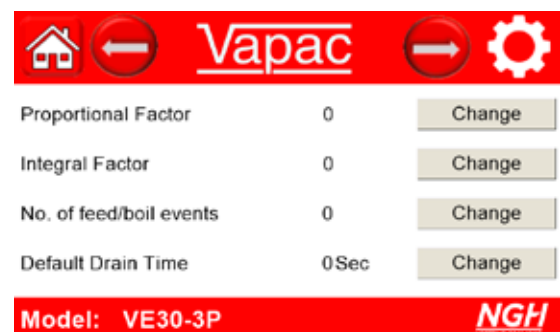

The Vapac controller will provide PID (proportional, integral and derivative) control when used with a humidity sensor.

In this instance:-

- The set proportional factor will be displayed. The proportional component depends only on the difference between the set point and the process variable. This difference is referred to as the Error term. The proportional gain determines the ratio of output response to the error signal.

For instance, if the error term has a magnitude of 10, a proportional gain of 5 would produce a proportional response of 50. In general, increasing the proportional gain will increase the speed of the control system response. However, if the proportional gain is too large, the process variable will begin to oscillate. This can be changed via a setting screen. The default value is 750.

- The set integral factor will be displayed. The integral component sums the error term over time. The result is that even a small error term will cause the integral component to increase slowly. The integral response will continually increase over time unless the error is zero, so the effect is to drive the Steady-State error to zero. Steady-State error is the final difference between the process variable and set point. This can be changed via a setting screen. The default value is 40.
- The set number of feed / boil events will be displayed. As a default the system is set to carry out 4 feed / boil events, before completing a default drain. The number of events can be increased or decreased if required to suit the specific site conditions.
- The set default drain time will be displayed. This setting is the time duration of the drain. The default setting is 3 seconds. This can be increased or decreased to suit the specific site conditions.

### 3. Commissioning Mode Page 3

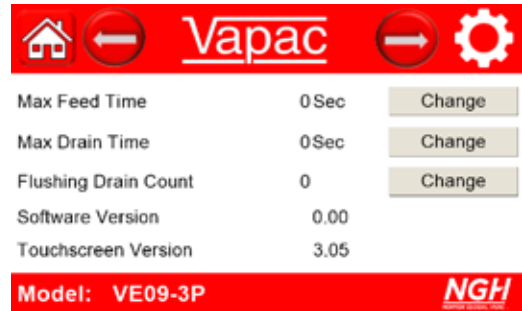

The set maximum feed time will be displayed. This setting is the time limit for the water to fill the cylinder to the fill pin before engaging a caution alarm. The default setting is 600 seconds. This may need adjusting to suit site specific water flow rate conditions.

The set maximum drain time will be displayed. This setting is the time duration of the drain. The default setting is 3 seconds. This can be increased or decreased to suit the specific site conditions.

The flushing drain count will be displayed. The unit has been designed to automatically undergo a flushing drain cycle (drain / fill / drain) after 72 hours of being in standby mode. The setting range is 1-20 drain / fill / drain cycles. The default setting is 1

The control board software version will be displayed.

The touchscreen software version will be displayed.

### 4. Commissioning Mode Page 4



By connecting via WIFI, you can remotely monitor and change settings via a Modbus application. An IP address will be automatically assigned in this instance. Please contact your Vapac distributor for further information.

## 5. Commissioning Mode Page 5

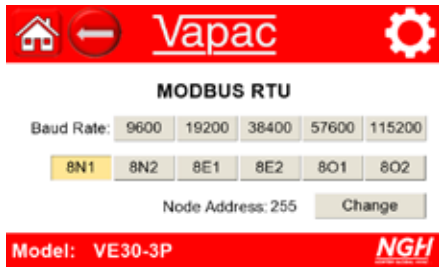

If the unit is connected to a Modbus input, the various Modbus settings can be adjusted via this page. Please contact your Vapac distributor for further information.

### Critical Alarm

A CRITICAL ALARM is raised if the current consumption increases above a preset maximum; if this occurs, the following screen will show and the unit will be prevented from operating.



### Service and Advanced Modes

These screen pages are for use by the Service Engineer. The separate Distributors Manual (only available to distribution partners) gives details of these modes.

### Service due indication

When a service is due, "Call Service" will show on the screen as per the example below. In this instance, contact the Vapac Distribution Partner to arrange a service visit as soon as possible.

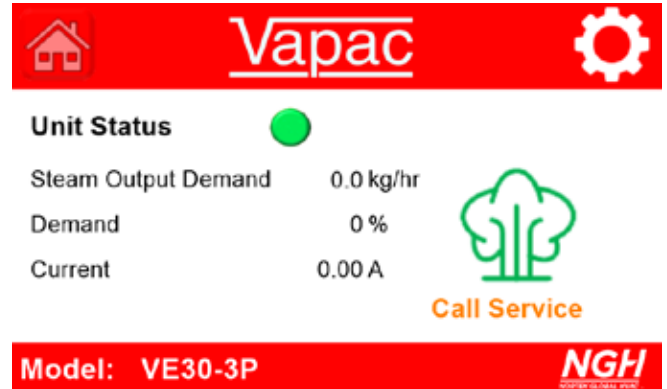

## Cylinder selection

The chart below details how to select the correct cylinder for the model of unit and the water conductivity range. Scotland is a typical "soft water" area; the midlands is a typical "normal water hardness" area; and London is a typical "hard water" area.

### Vapac Cylinder Selection for the standard VE Virtuoso Range

C

For cylinder type L, N or H refer to the water conductivity and unit type to select recommended cylinder

Cylinder Rating and Water Conductivity micro Siemens per cm											
Cylinder Voltage Band	80	100	200	300	400	500	600	700	800	900	1000
230 1 PH + N			L								H
400 3 PH		L			N						H

Unit Type	L	N	H
VE05-1P	D1-2L235	D1-2N235*	D1-2H235
VE09-1P	D2L235	D2N235*	D2H235
VE09-3P	D2L335	D2N335*	N/A
VE18-3P	D3L335	D3N335*	D3H335
VE30-3P	D4L355	D4N355*	D4H355
VE45-3P	D4L655	D4N655*	D4H655

#### Notes:

1. Stainless steel cylinder versions available on request.
  2. VE60-3P and VE90-3P humidifiers have two steam cylinders.
- \*Fitted as standard

The above is to be taken as a guide only.  
In exceptional circumstances alternatives may be required.



## Cylinder electric demand loads



Model	VE05-1P						
Cylinder		1	1				
Nominal Output	kg/hr	5.00	5.00				
Nominal Output	lb/hr	11.00	11.00				
Voltage	V	200	230				
Power input rating	kW	3.73	3.71				
Electrical Supply	Ph's	Ph+N	Ph+N				
No. of electrodes		2	2				
Full load Current	A	22.50	19.50				
Maximum overcurrent	A	25.9	22.45				
Fuse Rating/phase	A	40	32				
Supply cable terminals	mm <sup>2</sup>	10	10				
Wiring diagram		<a href="#">D301585</a>					
Cabinet size		A					

Model	VE09-1P						
Cylinder		1	1				
Nominal Output	kg/hr	9.00	9.00				
Nominal Output	lb/hr	19.80	19.80				
Voltage	V	200	230				
Power input rating	kW	6.71	6.76				
Electrical Supply	Ph's	Ph+N	Ph+N				
No. of electrodes		2	2				
Full load Current	A	40.50	35.50				
Maximum overcurrent	A	48.60	41.00				
Fuse Rating/phase	A	63	63				
Supply cable terminals	mm <sup>2</sup>	16	16				
Wiring diagram		<a href="#">D301585</a>					
Cabinet size		A					

Model	VE09-3P						
Cylinder		1	1	1	1		
Nominal Output	kg/hr	9.00	9.00	9.00	9.00		
Nominal Output	lb/hr	19.80	19.80	19.80	19.80		
Voltage	V	380	400	415	440		
Power input rating	kW	6.81	6.89	6.85	6.94		
Electrical Supply	Ph's	3Ph	3Ph	3Ph	3Ph		
No. of electrodes		3	3	3	3		
Full load Current	A	12.50	12.00	11.50	11.00		
Maximum overcurrent	A	14.38	13.80	13.23	12.85		
Fuse Rating/phase	A	20	20	20	20		
Supply cable terminals	mm <sup>2</sup>	10	10	10	10		
Wiring diagram		<a href="#">D301586</a>					
Cabinet size		A					

## Cylinder electric demand loads

Model	VE18-3P							
Cylinder		1	1	1	1			
Nominal Output	kg/hr	18.00	18.00	18.00	18.00			
Nominal Output	lb/hr	39.60	39.60	39.60	39.60			
Voltage	V	380	400	415	440			
Power input rating	kW	13.35	13.48	13.39	13.57			
Electrical Supply	Ph's	3Ph	3Ph	3Ph	3Ph			
No. of electrodes		3	3	3	3			
Full load Current	A	24.50	23.50	22.50	21.50			
Maximum overcurrent	A	28.18	27.03	25.88	24.73			
Fuse Rating/phase	A	32	32	32	32			
Supply cable terminals	mm <sup>2</sup>	16	16	16	16			
Wiring diagram		<a href="#">D301586</a>						
Cabinet size		A						

Model	VE30-3P							
Cylinder		1	1	1	1			
Nominal Output	kg/hr	30.00	30.00	30.00	30.00			
Nominal Output	lb/hr	66.00	66.00	66.00	66.00			
Voltage	V	380	400	415	440			
Power input rating	kW	22.35	22.38	22.32	22.41			
Electrical Supply	Ph's	3Ph	3Ph	3Ph	3Ph			
No. of electrodes		3	3	3	3			
Full load Current	A	41.00	39.00	37.50	35.50			
Maximum overcurrent	A	47.15	44.85	43.13	40.83			
Fuse Rating/phase	A	50	50	50	50			
Supply cable terminals	mm <sup>2</sup>	16	16	16	16			
Wiring diagram		<a href="#">D301586</a>						
Cabinet size		B						

Model	VE45-3P							
Cylinder		1	1	1	1			
Nominal Output	kg/hr	45.00	45.00	45.00	45.00			
Nominal Output	lb/hr	99.00	99.00	99.00	99.00			
Voltage	V	380	400	415	440			
Power input rating	kW	33.79	33.85	33.93	33.45			
Electrical Supply	Ph's	3Ph	3Ph	3Ph	3Ph			
No. of electrodes		6	6	6	6			
Full load Current	A	62.00	59.00	57.00	53.00			
Maximum overcurrent	A	71.30	67.85	65.55	60.95			
Fuse Rating/phase	A	80	80	80	80			
Supply cable terminals	mm <sup>2</sup>	35	35	35	35			
Wiring diagram		<a href="#">D301586</a>						
Cabinet size		B						

## Cylinder electric demand loads

Model	VE60-3P								
Cylinder		1	2	1	2	1	2	1	2
Nominal Output	kg/hr	30.00	30.00	30.00	30.00	30.00	30.00	30.00	30.00
Nominal Output	lb/hr	66.00	66.00	66.00	66.00	66.00	66.00	66.00	66.00
Voltage	V	380	380	400	400	415	415	440	440
Power input rating	kW	22.35	22.25	22.38	22.38	22.32	22.32	22.41	22.41
Electrical Supply	Ph's	3Ph	3Ph	3Ph	3Ph	3Ph	3Ph	3Ph	3Ph
No. of electrodes		3	3	3	3	3	3	3	3
Full load Current	A	41.00	41.00	39.00	39.00	37.50	37.50	35.50	35.50
Maximum overcurrent	A	47.15	47.15	44.85	44.85	41.13	41.13	40.83	40.83
Fuse Rating/phase	A	50	50	50	50	50	50	50	50
Supply cable terminals	mm <sup>2</sup>	16	16	16	16	16	16	16	16
Unit Total FLC	A	2 x 41		2 x 39		2 x 37.5		2 x 35.5	
Wiring diagram		<a href="#">D301587</a>							
Cabinet size		C							

Model	VE90-3P								
Cylinder		1	2	1	2	1	2	1	2
Nominal Output	kg/hr	45.00	45.00	45.00	45.00	45.00	45.00	45.00	45.00
Nominal Output	lb/hr	99.00	99.00	99.00	99.00	99.00	99.00	99.00	99.00
Voltage	V	380	380	400	400	415	415	440	440
Power input rating	kW	33.79	33.79	33.85	33.85	33.93	33.93	33.45	33.45
Electrical Supply	Ph's	3Ph	3Ph	3Ph	3Ph	3Ph	3Ph	3Ph	3Ph
No. of electrodes		6	6	6	6	6	6	6	6
Full load Current	A	62.00	62.00	59.00	59.00	57.00	57.00	53.00	53.00
Maximum overcurrent	A	71.30	71.30	67.85	67.85	65.55	65.55	60.95	60.95
Fuse Rating/phase	A	80	80	80	80	80	80	80	80
Supply cable terminals	mm <sup>2</sup>	35	35	35	35	35	35	35	35
Unit Total FLC	A	2 x 62		2 x 59		2 x 57		2 x 53	
Wiring diagram		<a href="#">D301587</a>							
Cabinet size		C							

# Commissioning and operation



**Vapac VE Humidifiers must be commissioned before being put into service.**

**Do not permit the area around the humidifier to become damp or wet. If dampness occurs, turn the output of the humidifier down. If the humidifier output volume cannot be turned down, use the humidifier intermittently. Do not allow absorbent materials, such as carpeting, curtains, drapes, or tablecloths, to become damp.**

**Be aware that high humidity levels may encourage the growth of biological organisms in the environment.**



**Never leave water in the steam cylinder when the appliance is not in use; always drain it fully.**

## Pre-start checks

- The steam line should be connected as detailed in the installation section previously and in accordance with all relevant local and national regulations
- The water supply(ies) should be connected as detailed in the installation section previously and in accordance with all relevant local and national regulations. The water supply line should be flushed prior to use.
- The drain connection(s) should be connected as detailed in the installation section previously and in accordance with all relevant local and national regulations.
- The power supply(ies) should be provided as detailed in the installation section previously. All wiring must be carried out by a qualified electrician and must comply with the relevant regulations using appropriately sized cable and cable glands, with disconnect and fuses to suit the maximum fuse rating of the unit at the supply Voltage. The disconnect / fuses should be adjacent to the unit or within easy reach and readily accessible.

- The control input connections should be provided as detailed in the installation section previously and in accordance with the wiring diagrams provided in the appendices at the rear of this manual.
- The correct tapping to suit the main incoming supply voltage must be selected on the control transformer via wire TX.

## Start up



**For your safety, follow the instructions exactly otherwise damage or injury could occur!**

1. Ensure that the I/O/II switch on the fascia of the unit is in the "O" (Off) position. 
2. Check that the control transformer connection matches the supply voltage.
3. Check that the control circuit is calling for unit operation.
4. Close the electrical access panel.
5. Close the disconnect / circuit breaker feeding the electrical supply to the unit.
6. Select the "I" (Run) position on the I/O/II switch on the fascia of the unit.
7. The display will now show the initial setup procedure as discussed on page 27.
8. Select the preferred language.
9. Select the required single phase voltage (VE05-1P / VE09-1P) or three phase voltage (all other models) as applicable.
10. Select control input type as applicable.
11. The normal operation mode screen will be displayed (standby, steaming, filling, draining, caution alarm) as applicable.

## Commissioning checks

Once the above setup procedure has been carried out, the unit is available to operate according to the requirements of the control signal and set parameters.

During initial operation, the following should be checked:-

- the water and steam installation for any leakage.
- the humidifier for any signs of damage.
- the humidifier and steam pipe fixings for security.
- the electrical installation for any signs of damage.
- the display panel for caution or critical alarm indication.

## Commissioning - hand over

Upon full and satisfactory completion of commissioning, a record of commissioning information should be left with the person responsible for the humidifier.

The commissioning engineer must ensure that the user is familiar with the safe and efficient use of the unit, detailing the function of all controls and main components.

The user should be made aware of the following in particular: -

- Start up, shutdown and operational information.
- Safety features, data plate, and labelling.
- The requirement for regular inspection - especially if the humidifier is within a more demanding environment - and the need for regular servicing carried out by a suitably qualified person.

## Operation

With the I/O/II switch in the "I" (Run) position, whenever steam is required the electrodes are supplied with voltage via the main contactor. Simultaneously, the water inlet valve opens and water enters the steam cylinder.

As soon as the electrodes come into contact with the water, current begins to flow between the electrodes, generating heat and increasing the water evaporation rate, in turn producing steam.

As more of the electrode surface area is exposed to conductive water, the higher the current consumption becomes and thus the greater the steam production.

Upon reaching the required steam capacity, the water inlet valve closes.

If the steam generation decreases below a certain percentage of the required capacity, due to the lowering of the water level (e.g. because of the evaporation process or drainage), the water inlet valve opens until the required capacity is available again.

If the required steam capacity is lower than the actual output, the water inlet valve is closed until the desired capacity is achieved by the lowering of the water level (evaporation process).

A cylinder full electrode sensor, provided in the steam cylinder, detects when the cylinder water level is at the maximum. When the sensor comes in contact with water, the water inlet valve will close after a short delay.

As a result of the evaporation and refill process, the conductivity of the water increases due to an escalating mineral concentration. Eventually, an inadmissibly high current consumption would take place if this concentration process were permitted to continue. To prevent this concentration from reaching a value unsuitably high for the operation, a quantity of water is periodically drained from the cylinder and replaced by fresh water.

When starting with an empty cylinder, the Vapac controller switches in the contactor and feeds water until the water level reaches the electrodes and current starts to flow.

Thereafter, the system will continuously monitor and control the cylinder conductivity by adjusting the amount of water drained from and fed into the cylinder in the manner described earlier.



The controller has been designed to adjust the feed and drain to keep the unit operating in the face of changing water quality in the cylinder and changing electrode condition even if, in an adverse operational circumstance, this results in some reduction in output while the situation exists.

Additionally, the control system has been designed to prevent the onset of foaming; introducing corrective drainage to keep the unit working.

## Operational Status Indication

With power to the unit and the I/O/II screen in the "O" (Off) position, the touch screen display panel will show the STANDBY screen.

**STANDBY** is part of the normal operation of the unit - it is ready for operation.

With power to the unit and the I/O/II switch in the "I" (Run) position, the touch screen display panel will provide status indication of the following:-

- STANDBY
- STEAMING
- FILLING
- DRAINING
- CALL SERVICE
- CAUTION ALARM
- CRITICAL ALARM

**STEAMING** is part of the normal operation of the unit - current is being supplied to the electrodes and steam is being produced.

**FILLING** is part of the normal operation of the unit - the feed valve is opened to add water to the cylinder until the electrode current reaches its target.

**DRAINING** is part of the normal operation of the unit - the drain pump is run for a preset time by the controller. A default drain occurs after a set number of feed / boil cycles.

An override drain occurs if the electrode current approaches its high limit and stops once the electrode current drops below the cylinder maximum operating current.

**CALL SERVICE** is part of the normal operation of the unit - when this screen shows, it is an indication to the end user that a service is due and a service engineer should be called out.

**CAUTION ALARM** is initiated by one of the following conditions; if any one occurs, the unit will continue to operate:-

- Cylinder low output
- Feed fault
- Drain fault
- No voltage to controller

**CRITICAL ALARM** is raised if the current consumption increases above a preset maximum; if this occurs, the unit will be prevented from operating.



**Caution and critical alarms can only be reset by the service engineer.**

## Unit frost protection

A thermistor has been provided within the electrical section of the unit to operate in conjunction with the controller to provide frost protection of the unit.

The settings for frost protection can only be altered by a service engineer from the touch screen. The default setting for frost protection is "deactivated" i.e both the setpoint and output values are set to zero.

If frost protection is required, the setpoints should be adjusted accordingly; e.g. a typical setpoint would be 5°C at an output of 50%, meaning if the sensed temperature drops below 5°C, the unit will operate at 50% output until the sensed temperature rises above 5°C. This is adjustable from 0% to 50% and 0°C to 15°C.

## Taking the unit out of operation

In order to take the unit out of operation e.g. for maintenance purposes, follow the steps given below:-

1. If the unit has been switched off due to an alarm condition, note the message shown on the display panel.
2. Close the shut-off valve in the water supply to the humidifier.
3. With the power connected to the unit, manually drain the cylinder by pressing and holding down the I/O/II switch on the fascia of the unit in the "II" (Drain) position until the cylinder has fully drained.
4. Return the I/O/II switch to the "O" (Off) position.
5. Isolate the electrical supply to the humidifier.
6. Allow the unit to cool down.
7. If the unit could be exposed to frost, drain the incoming water pipe and the water filter.



# Maintenance

## Maintenance schedule



**Before commencing, turn off the water supply, drain the cylinder, switch off the main electricity supply and allow the cylinder(s) to cool.**

**Never leave water in the steam cylinder when the appliance is not in use; always drain it fully.**

**Always consult your distributor at the slightest doubt.**

MS



The unit will operate with a minimum of maintenance. It is recommended that maintenance is carried out at least once a year by a suitably qualified person. More frequent servicing may be required dependent upon the environmental circumstances where the unit is installed. Regular inspection is necessary, especially in dirty areas, to assess the servicing frequency.

The following procedures should be carried out at least once each year:-

- Generally clean the exterior of the unit using a damp cloth.
- Repair any damage to the unit.
- Carry out cylinder exchange (may be required more frequently).
- Inspect water feed and clean or replace the feed valve inlet strainer (see page 42) if found necessary.
- Inspect condensate drain and replace pump if necessary.
- Inspect steam hoses for cracks and correct attachment to the unit. Repair any damage found / replace.
- Inspect pipework connections and water hoses and repair any damage found / replace.
- Inspect all cables and electrical connections for tightness and security.

## Steam cylinder replacement

The water hardness and the humidity demand on site will determine the effective life of a steam cylinder. Units located in areas with naturally soft water will experience longer cylinder life. With hard water, a more frequent exchange of cylinders must be expected.

The cylinder selection chart given on page 33 previously details the cylinders required for each model based on soft, normal and hard water hardness.

Scaling up of the Vapac steam cylinder is normal and is outside the Vapac warranty.



**Fig 15 - steam cylinder showing electrode caps**

To exchange a steam cylinder:-

1. With the power connected to the unit, manually drain the unit by pressing and holding down the I/O/II switch on the fascia of the unit in the "II" (Drain) position until the cylinder has fully drained.



2. Disconnect the unit from the incoming electrical supply by means of the adjacent external isolator (disconnect switch). This should be "locked off" to prevent accidental operation.
3. Remove the front access panel(s) to gain access to the steam cylinder(s).
4. Remove the cylinder spring clip, then carefully ease off (lever) the black electrode caps and the white cylinder full sensor cap.
5. If the cylinder is to be replaced, care should be taken not to twist the electrode caps while removing the black power caps. The electrodes can rotate in the cylinder bosses (if the plastic cylinder is hot) and lead to unbalanced electrical loads.
6. Loosen the hose clip and disconnect the steam hose from the top of the cylinder.
7. Using a twisting movement, lift the cylinder clear of its seating in the feed / drain manifold and carefully remove the used cylinder from the unit.
8. Inspect the feed / drain manifold to ensure it is clear of sediment.
9. Insert the cylinder into the feed / drain manifold, pushing it down firmly to ensure it is seated correctly and replace the cylinder spring clip.
10. Reconnect the steam hose using the hose clip.
11. Replace the electrode caps ensuring that they are replaced in the same sequence as when removed. With the cylinder full pin towards the front of the unit, electrode number 1 will be to the left of the white cylinder full electrode. Electrodes 2, 3 etc. will be sequentially connected clockwise around the cylinder (from number 1), when viewed from above. Please first tighten the nut in each electrode plug.



12. The connections to the cylinder should be routed as close as possible to their original route.

## Cleanable steam cylinders

Cleanable versions of the steam cylinders are available which can be opened to allow removal of loose scale deposit. The cylinder design is the same as the standard cylinder but instead of a welded join, the two parts are brought together by a seal and two clamping rings with quick-release fasteners. The equivalent cleanable cylinder may be ordered via your Vapac Distribution Partner.

MS

When servicing a cleanable cylinder, take it to an area where it is convenient to open it up and dispose of the contents. When cleaning out loose material also remove any build-up on the end of the short "cylinder full" electrode.

Make sure the slotted strainer is clean, intact and in place. When re-assembling, use a new seal and make sure the mating surfaces are free of scale particles as they will prevent a perfect seal and cause leaks.



**Do not touch an operating cleanable cylinder in case there is a leak allowing water with a voltage applied to seep out.**

**Do not interfere with the electrodes in a cleanable cylinder; if they are badly eroded and / or the internal positioning ring is free, a new cylinder should be used.**

## Steam hoses

The steam hoses used with the unit externally and internally should be inspected as part of normal maintenance procedures. At the first signs of deterioration, the steam hose should be removed and replaced.

## Tundish

We recommend cleaning the filling cup once a year as part of maintenance. Pumping loose deposits can damage the arch. If the arch is damaged, the tundish assembly should be replaced as some of the pumped water can run back into the cylinder via the inlet hose and cause a blowdown error.

MS



### Feed valve with strainer

The nylon bodied solenoid feed valve incorporates a small nylon strainer which is a push fit into the inlet of the valve. With a new plumbing installation, residual loose solid material in the pipework could partially block the strainer after start-up.

If for this, or any other reason, a restriction of the water flow is suspected (outside of supply pressure considerations), it is possible to clean the strainer in the following manner:-

1. Ensure the I/O/II on the fascia of the unit is in the '0' (Off) position.
2. Isolate the electrical supply to the unit.
3. Turn off the water supply to the Unit.
4. Undo the nylon nut connecting the flexible connection to the valve inlet.
5. The strainer can be removed using 'long-nosed' pliers to grip the centre flange provided on the strainer for this purpose.
6. Withdraw the strainer and wash it with cold running water.
7. Replace the strainer and reconnect the nylon nut / flexible connection.

8. Turn on water supply.
9. Reconnect electrical supply to allow unit to operate.

Note: Always replace the strainer after cleaning as it is required to prevent material lodging in the valve seat or blocking the small flow control restrict or which is fitted in the valve.

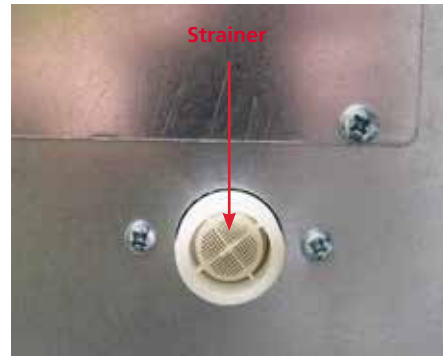

**Fig 16 - view from bottom of unit showing feed valve inlet strainer**

### Bottom access panel

An access panel has been provided at the bottom of the unit, held in place by screws. Removal of the panel allows access to the drain pump and feed / drain manifold assembly

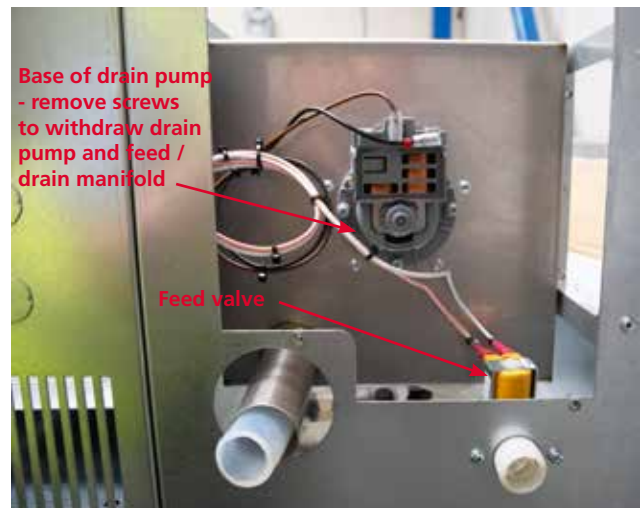

**Fig 17 - bottom panel removed for access to drain pump and feed / drain manifold assembly**

## Drain pump and feed / drain manifold

The feed / drain manifold should be visually checked to ensure that the feed and drain ports are not blocked. Any debris found should be removed.

The drain pump is a sealed unit and should not be dismantled. To remove / replace the pump:-

1. Place a bucket below the pump to catch any water remaining in the housing or pipework.
2. Undo the screws holding the pump body to the feed & drain manifold and remove it - any water trapped in the pump will be released at this point.
3. Fit the replacement pump by following the above steps in reverse order. Ensure that the pump is correctly seated and that it mates correctly with the feed / drain manifold and gasket.

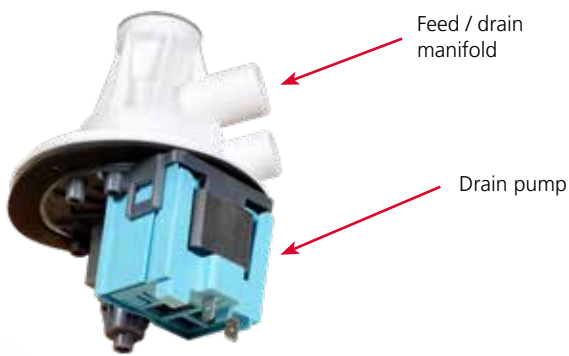

**Figure 18 - Drain pump and filling and drain socket**

# Fault Finding

Fault	Possible Cause	Remedy / Action
Humidifier does not operate	Power supply is OFF	Check the main power supply disconnect switch and circuit breakers. Remedy any fault found then re-instate the supply
	I/O/II Switch in "O" Position	Select the "I" (Run) position on the I/O/II switch
	Fuse F1 or F2 blown	Check the fuses. Investigate cause if found to be blown then replace. Both fuses are rated at 2A.
	Wiring harness not properly secured	Check the wiring harness connections are secure and properly made.
Display blank	Power supply is OFF	Check main power is connected and switched on.
		Check power supply fuses / MCBs and replace / reset if necessary.
	Display fault	Contact Vapac Distributor
Automatic stop occurred	Feed fault indicated on display	Water supply is not connected - check water stop valve is open
		Water supply connected but not reaching cylinder - check internal hose connections for leaks
		Contact Vapac Distribution Partner
	Drain fault indicated on display	Drain pump function impaired. If pump will not function, empty cylinder by disconnecting at the tun-dish fill-cup the water supply hose to the cylinder and draining the water into a bucket. Remove, dismantle and clean pump.
		Cylinder outlet blocked - check and unblock

FF

Fault	Possible Cause	Remedy / Action
Humidifier on line but does not provide steam - no demand	No on / off demand signal (if used as input - terminals 57 and 59)	Verify the requirement from / setting of the control input
	No 0-10V DC external demand signal (if used as input - terminals 58 and 59)	Verify the requirement from / setting of the control input
	No demand from Humidity Sensor (if used as input - terminals H0V, H24V, 60, 61 and 62)	Verify the setting of the Humidity sensor. The setting can be changed from commissioning screen page 1
	Fire stop / fire alarm interface operated (if fitted - terminals 13 and 14)	Check the EPO / fire alarm interface for operation and reset after investigating cause.
	Airflow not detected by airflow / pressure switch (if used e.g. humidifier is part of an AC or AHU system - terminals 13 and 14)	Check the fan operation and reset after investigating cause
	Fan interlock operated (if fitted e.g. humidifier is part of an AC or AHU system - terminals 13 and 14)	Check the fan operation and reset after investigating cause
	High limit humidistat has operated (if fitted - terminals 13 and 14)	Check the humidistat and reset after investigating cause
	Control wires are not properly secured to the terminal blocks	Check and secure the connections of the control wires to the terminal blocks
Humidifier on line but inadequate or no steam production	Cylinder fault	Replace as necessary
No water in the steam cylinder or humidifier does not stop draining	Humidifier is being filled with water but has not yet reached the water high level sensor	Check that the drain pump is off
		Check that the shut off valve on the water supply line is fully open
		Verify the operation of the fill valve
	Humidifier is not being filled with water	Check that a water supply is available Contact Vapac Distribution Partner
Humidifier does not drain	Drain pump is clogged	Contact Vapac Distribution Partner
	During a drain cycle, the water level sensor has sensed that the water level is not decreasing	Check the fill and drain water pipe connections and remedy any fault found (e.g. blocked drain pump, etc.)
		Contact Vapac Distribution Partner
"Call Service" at display	The set service hours have elapsed and a service is due. The service interval is set at commissioning being specific to the actual site requirements and conditions.	Contact Vapac Distribution Partner.
"Caution Alarm" and fault code shown on display. The unit continues to operate.	A caution alarm will occur in the event of the following:- <ul style="list-style-type: none"> <li>• Cylinder low output</li> <li>• Feed fault</li> <li>• Drain fault</li> <li>• No voltage to controller</li> </ul>	Contact Vapac Distribution Partner
"Critical Alarm" and fault code shown on display. The unit is stopped from operating.	A critical alarm will occur if the current consumption increases above a preset maximum.	Contact Vapac Distribution Partner

# Spare Parts

Part Number	Description	Application
1038535	Control Wiring Harness	VE05-1P, VE09-1P
1038536	Control Wiring Harness	VE09-3P, VE18-3P, VE30-3P and VE45-3P
1038537	Control Wiring Harness	VE60-3P, VE90-3P
1038210	Power Wiring Harness	VE05-1 P
1038511	Power Wiring Harness	VE09-1 P
1038551	Power Wiring Harness	VE09-3P, VE18-3P, VE30-3P
1038552	Power Wiring Harness	VE45-3P
1038553	Power Wiring Harness	VE60-3P
1038554	Power Wiring Harness	VE90-3P
1240119	Transformer 70VA	All VE range models
1170148-1	SSR	All VE range models
1038389	1 and 2 Phase EMC Filter	All VE range models
1038390	3 Phase EMC Filter	All VE range models
1037436	Heatsink	All VE range models
1080095	Fuse-2A	All VE range models
1080075	Fuse-630mA	All VE range models
1023411	Fuse Holder	All VE range models
1023412	Fuse Holder End Plate	All VE range models
2600070-1	Drain Pump	All VE range models
2620320	Solenoid Valve 1.2L	VE05-1 P, VE09-1 P, VE09-3 P, VE18-3P
2620325	Solenoid Valve 2.5L	VE30-3P, VE45-3P, VE60-3P, VE90-3P
1038122	OPTO PCB	All VE range models
1038121	Current Transformer 100A	All VE range models
1038531	Titan Controller	All VE range models
1038532	Titan Relay Module	All VE range models
1038534	RJ11 Link Cable	All VE range models
1038533	12V Power Supply Unit	All VE range models
1038373	Double Pole Off-On-Momentary Switch with Markings I / 0 / II	All VE range models
1038123	5" Touch Screen and connection lead	All VE range models
1037411	Lift off Panel Assembly, Handles and Locks (Case A)	VE05-1 P, VE09-1 P, VE09-3P, VE18-3P
1038062	Lift off Panel Assembly, Handles and Locks (Case B)	VE30-3P, VE45-3P
1037978	Lift off Panel Assembly Set, Handles and Locks Left Hand and Right Hand Panels (Case C)	VE60-3P, VE90-3P
1038317	Fill / Tundish Assembly	VE05-1P, VE09-1 P, VE09-3P, VE18-3P
1038318	Fill / Tundish Assembly	VE30-3P, VE45-3P
1038319	Fill / Tundish Assembly - Twin Assembly	VE60-3P, VE90-3P
M990168	Tundish Assembly with Stainless Feed Pipe	All VE range models
3910195	Water Feed / Drain Manifold	All VE range models
2160120	Gasket for Water Feed / Drain Manifold	All VE range models
1038594	NTC 10K Thermistor with 30cm Lead (Frost Protection)	All VE range models
1038664	Touchscreen CR1220 Button Battery, 3V, 12.5mm Diameter	All VE range models

For replacement steam cylinders, contact your Vapac Distribution Partner or Vapac directly. The table on page 30 details how to select the correct cylinder for the model of unit and the water conductivity range.

# Electrical Components

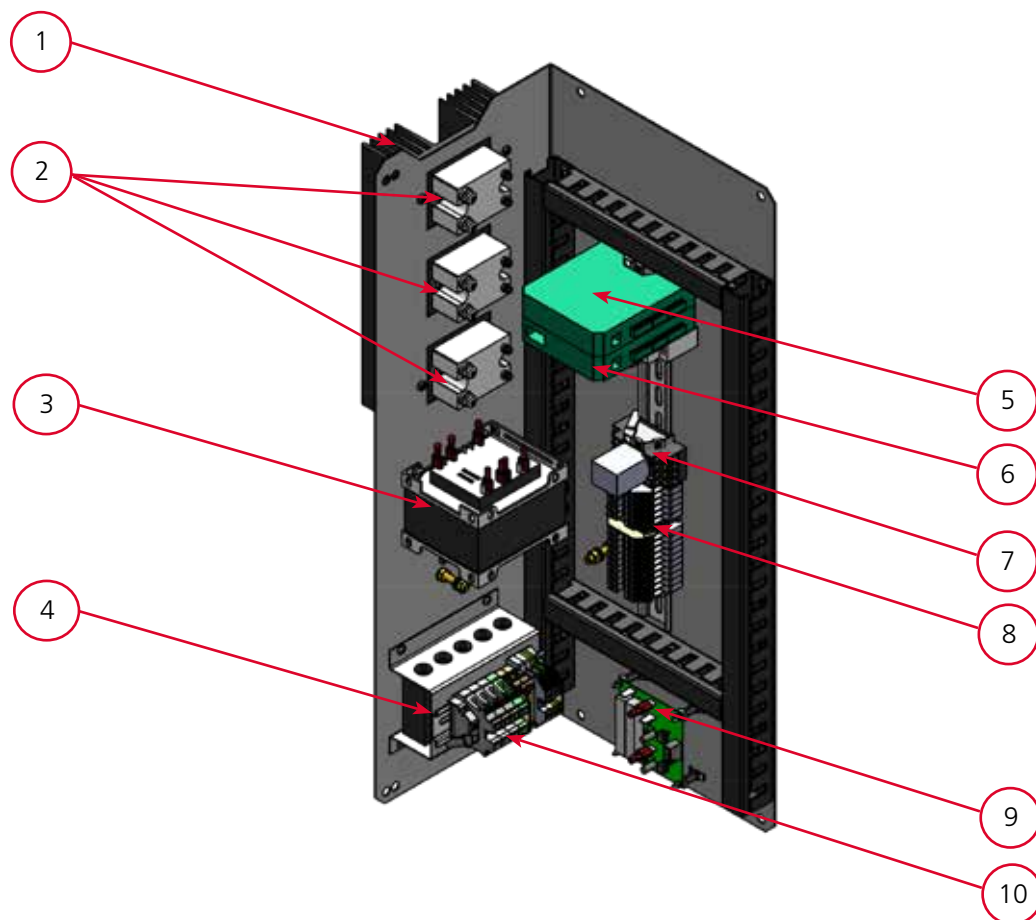

Ref	Description	Ref	Description
1	SSR Heatsink	6	Titan Relay Module
2	SSR Relay	7	24V Relay and Base
3	Transformer 200-440V	8	Terminal Strip
4	EMC Filter and Current Transformer	9	Opto PCB
5	Titan T32 Controller	10	Incoming Power Terminals

# Mechanical Components

Model VE05-1P, VE09-1P, VE09-3P, VE18-3P (Case A)  
 Model VE30-3P and VE45-3P (Case B)

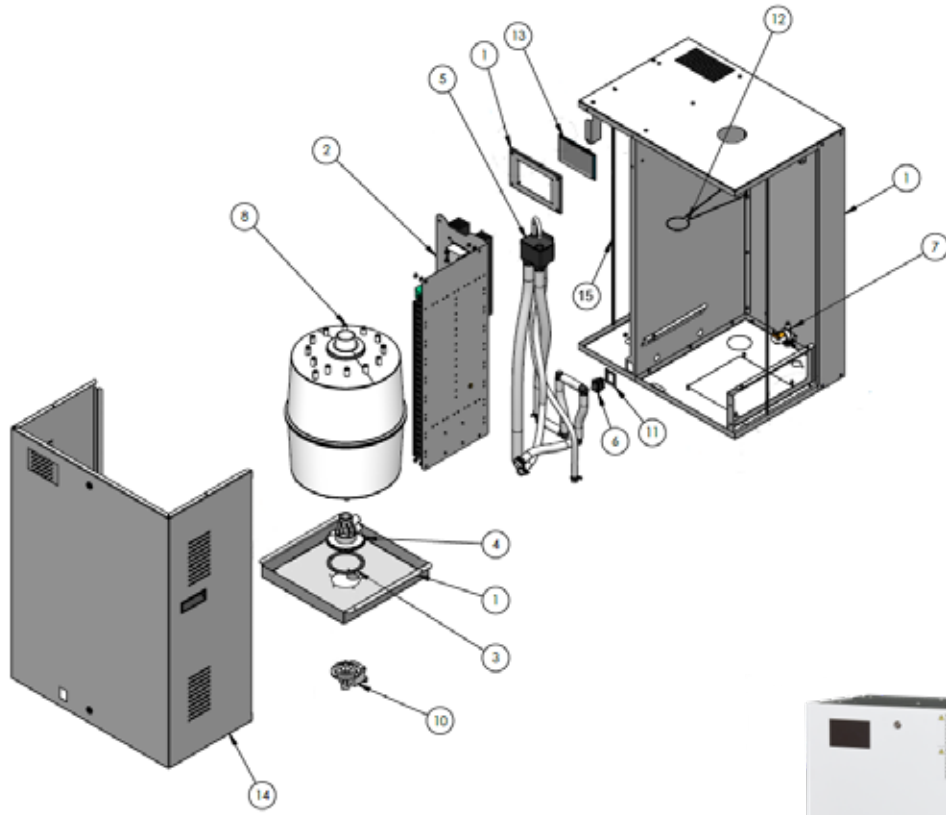

SP

Ref	Description		Ref	Description	
1	Case A Assembly	VE05-1P, VE09-1P, VE09-3P, VE18-3P	8	Cylinder	
	Case B Assembly	VE30-3P, VE45-3P			
2	Single control electrical back plate assembly		9	Not used	
3	Gasket for pump housing		10	Drain pump	
4	Water feed / drain manifold / pump housing		11	Switch gasket	
5	Fill / tundish assembly		12	Cylinder wire retainer assembly	
6	I/O/II (Run / Off / Drain) switch		13	5" Touch screen display	
7	Water inlet valve assembly		14	Case A front panel	VE05-1P, VE09-1P, VE09-3P, VE18-3P
				Case B front panel	VE30-3P, VE45-3P



### Model VE60-3P, VE90-3P (Case C)

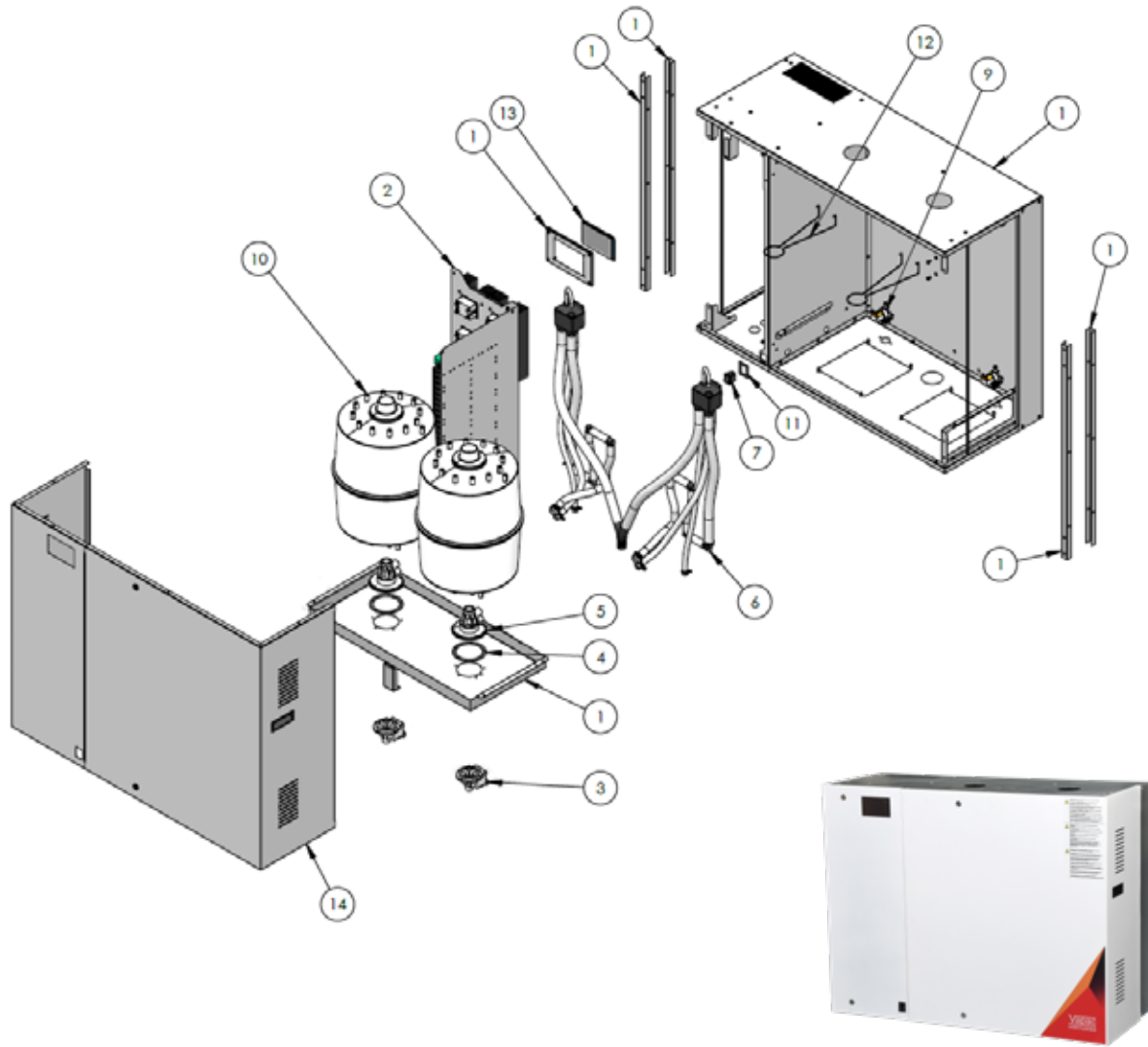

Ref	Description	Ref	Description
1	Case C Assembly	8	Not used
2	Double control electrical back plate assembly	9	Water inlet valve assembly
3	Drain pump	10	Cylinder x 2
4	Gasket for pump housing	11	Switch gasket
5	Water feed / drain manifold / pump housing	12	Cylinder wire retainer assembly
6	Fill / tundish assembly	13	5" touch screen display
7	I/O/II (Run / Off / Drain) switch	14	Case C front panel assembly (LH and RH)

## Taking the unit out of operation

---

To take the device out of operation for maintenance purposes, for example, proceed as follows:-

1. If the device has been switched off due to an alarm condition, note the message on the display.
2. Close the shut-off valve in the water supply to the humidifier.
3. When the power is connected, empty the cylinder manually by pressing and holding the I/O/II switch on the panel of the device in position "II" (emptying) until the cylinder is completely empty.
4. Set the I/O/II switch to "O" (Off).
5. Disconnect the electrical supply to the humidifier.
6. Allow the appliance to cool.
7. If the device could be exposed to frost, drain the water pipe and water filter.

## Decommissioning / disposal

---

When the humidifier needs to be replaced or is no longer needed:-

SP

1. Take the unit out of operation in the manner discussed above..
2. A suitably qualified technician should upgrade the humidifier and related components/services using the appropriate PPE and taking into account the weight of the device.

The humidifier and its associated components **MUST** be disposed of in accordance with "Waste Electrical and Electronic Equipment (WEEE) 2012/19/EU" and all other national and local regulations at an authorized collection point and **MUST NOT** be disposed of in household waste. The components should be recycled wherever possible.



This page is intentionally blank

# Appendix 1 - Wiring diagram single phase units

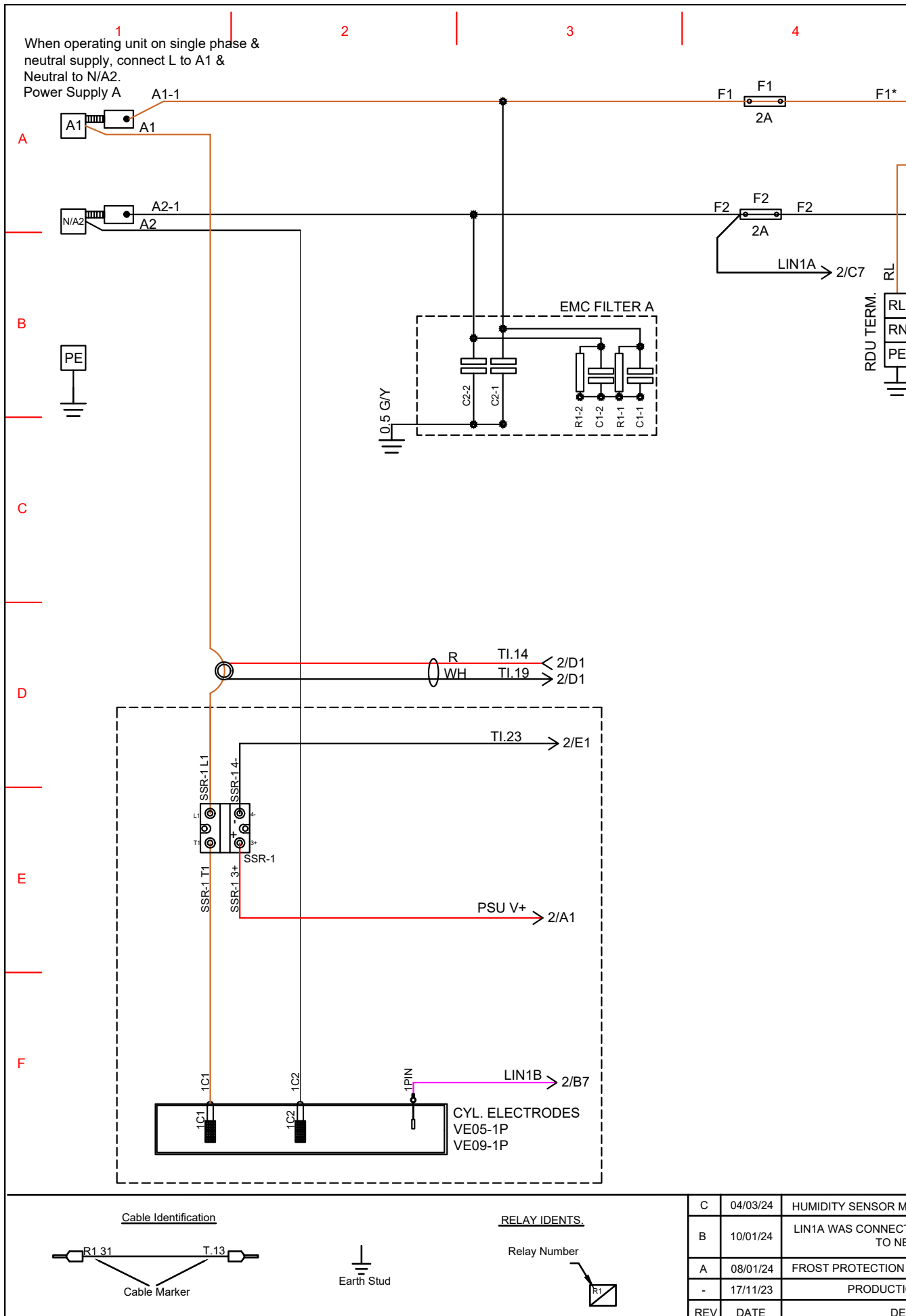

A1

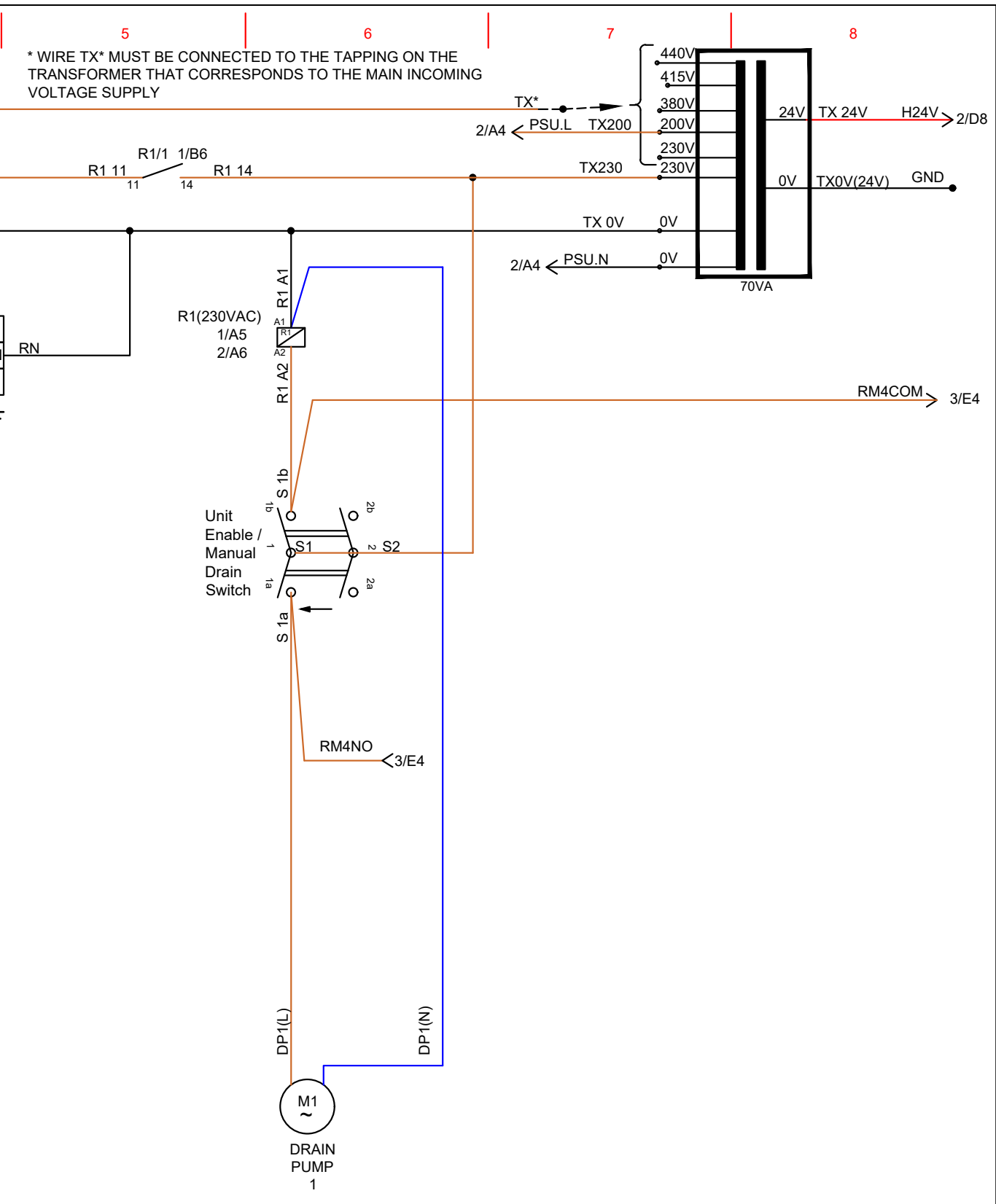

A1

MODIFIED - QA9138	TITLE VAPAC VE T32 SINGLE PHASE WIRING SCHEMATIC VE05-1P / VE09-1P	DRAWN	LW	 <b>ALWAYS MOVING FORWARD. NEVER STANDING STILL.</b>
TESTED TO LIVE, NOW CONNECTED NEUTRAL - QA9088		DATE	17/11/23	
TEMPERATURE THERMISTOR ADDED - QA9082	CLIENT	CHECKED		DRAWING No. D301585
ON RELEASE - QA9007	STANDARD	APPROVED		REVISION C
DESCRIPTION				SHEET 1 of 3

A1

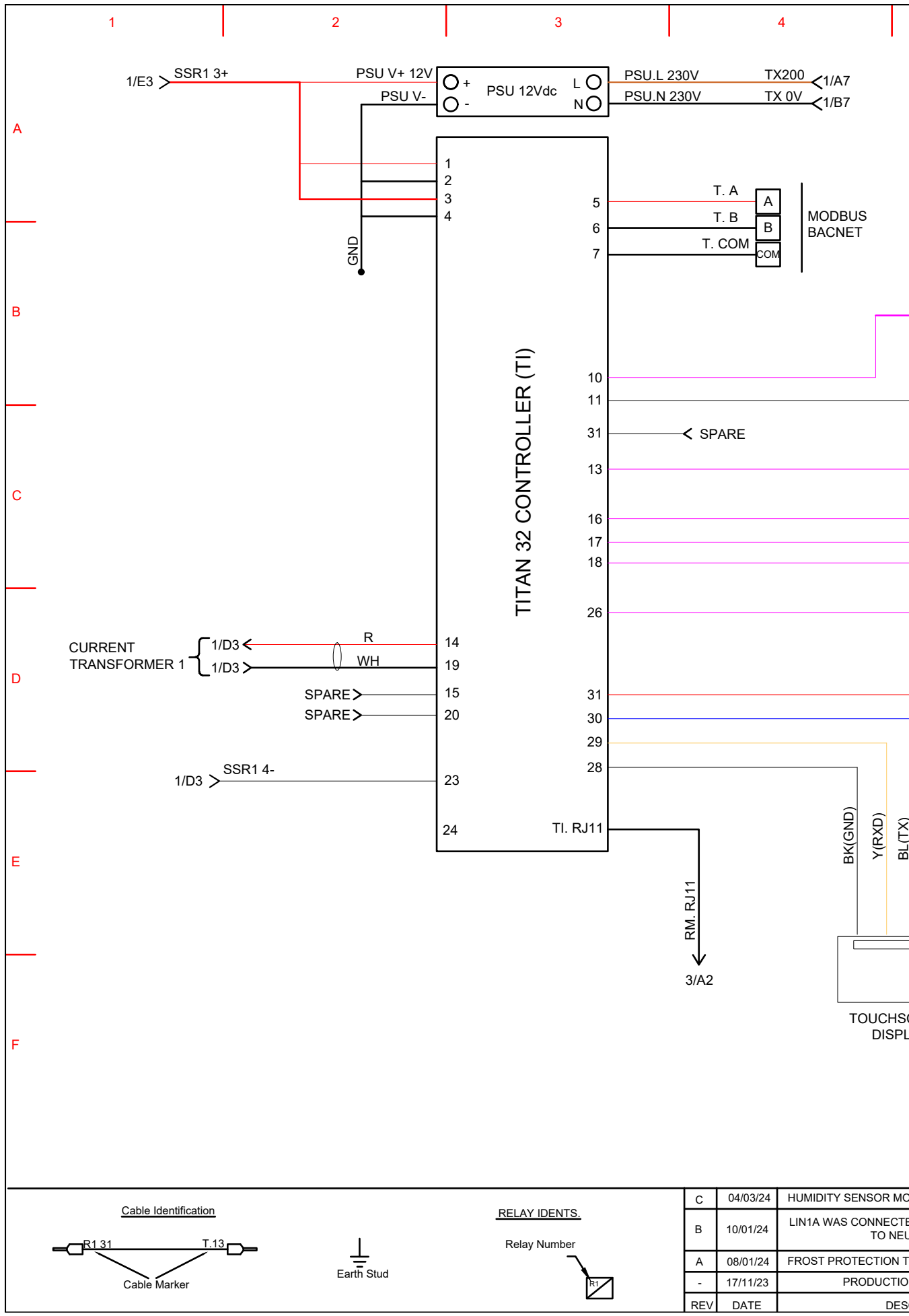

Cable Identification

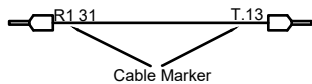

RELAY IDENTS.

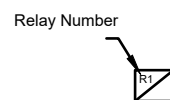

C	04/03/24	HUMIDITY SENSOR MO
B	10/01/24	LIN1A WAS CONNECTE TO NEU
A	08/01/24	FROST PROTECTION T
-	17/11/23	PRODUCTIO
REV	DATE	DES

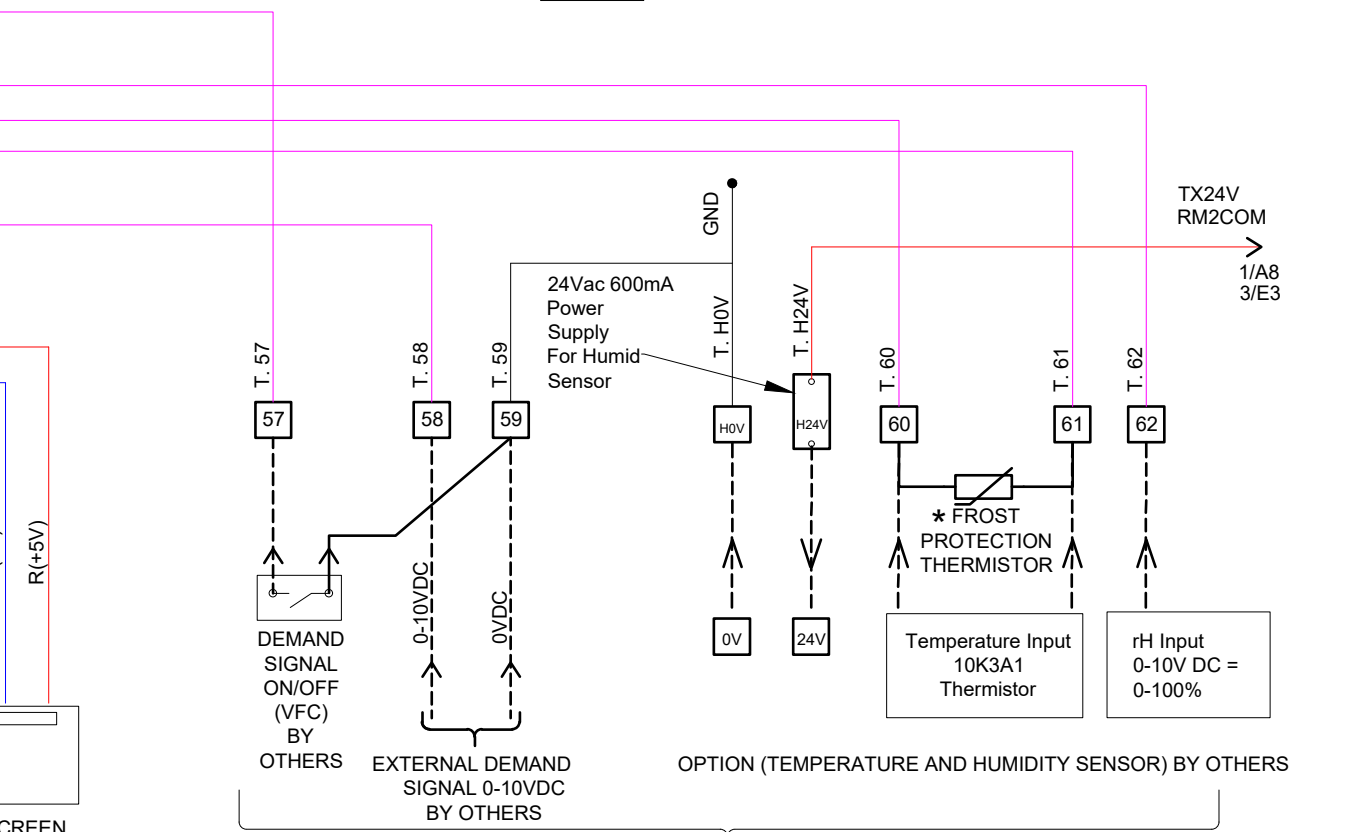
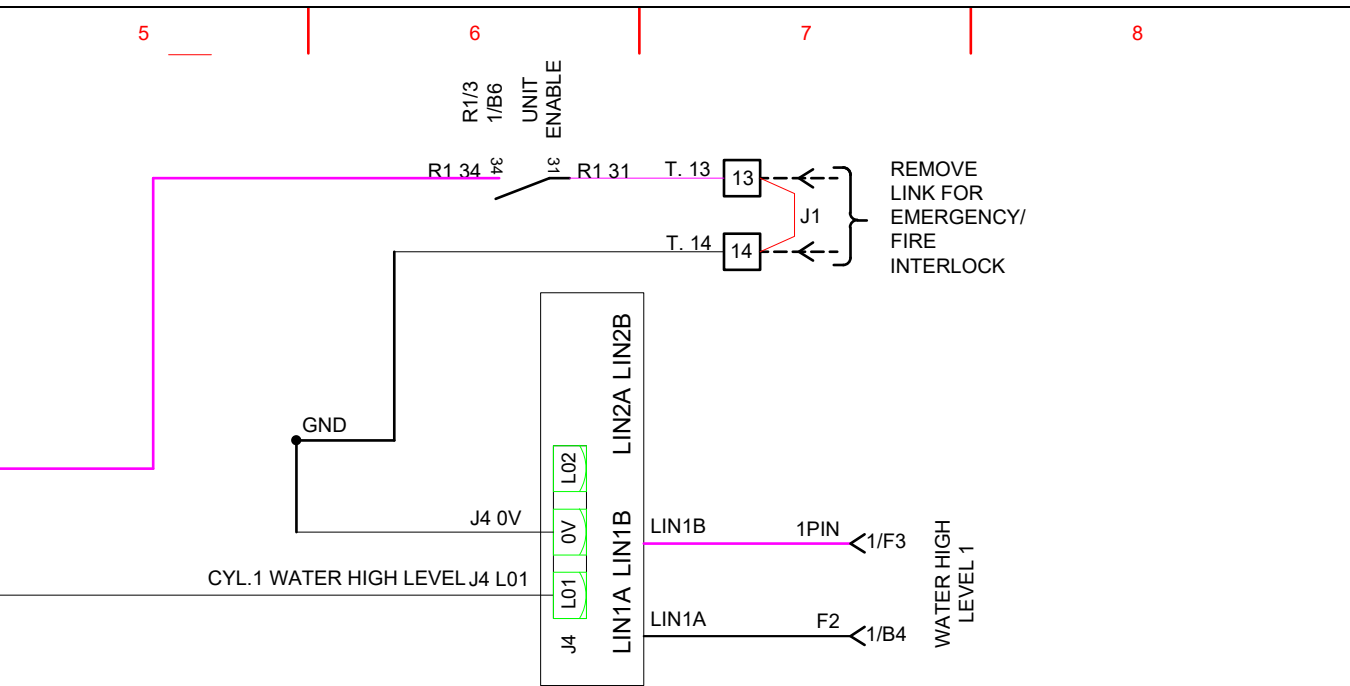

A1

**NOTE: ONLY ONE INPUT TO BE ALLOWED FROM THE ABOVE.  
 FOR TEMPERATURE SENSORS WITH 0-24V OUTPUT USE TERMINALS T60 AND T61  
 FOR TEMPERATURE SENSORS WITH 0-10V OUTPUT USE TERMINALS T58 AND T59**

**FACTORY FITTED FROST PROTECTION THERMISTOR TO BE REMOVED  
 IF ALTERNATIVE INPUT IS FITTED**

Fens Pool Avenue  
 Shirley Hill  
 West Midlands DY5 1QA  
 Tel: 01384 489 700  
 Fax: 01384 489 707

**ALWAYS MOVING FORWARD. NEVER STANDING STILL.**

MODIFIED - QA9138	TITLE VAPAC VE T32 SINGLE PHASE WIRING SCHEMATIC VE05-1P / VE09-1P	DRAWN	LW	ALWAYS MOVING FORWARD. NEVER STANDING STILL.	
ED TO LIVE, NOW CONNECTED UTRAL - QA9088		DATE	17/11/23	JOB No	
HERMISTOR ADDED - QA9082	CLIENT	CHECKED		DRAWING No. D301585	
N RELEASE - QA9007	STANDARD	APPROVED		REVISION c	SHEET 2 of 3
SCRIPTION					

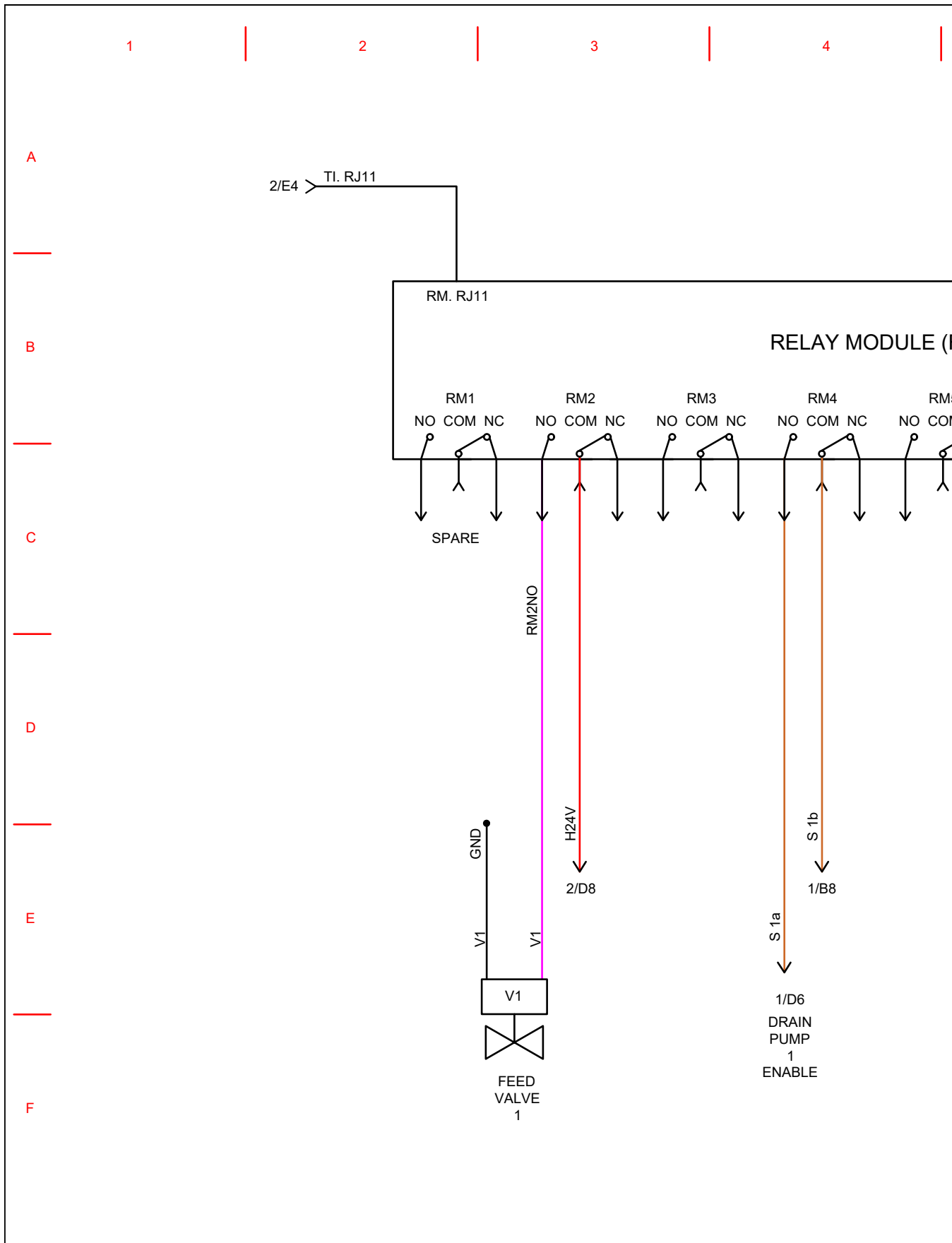

A1

REV	DATE	DESCRIPTION
C	04/03/24	HUMIDITY SENSOR MC
B	10/01/24	LIN1A WAS CONNECTED TO NEU
A	08/01/24	FROST PROTECTION T
-	17/11/23	PRODUCTION

<p><u>Cable Identification</u></p>	<p><u>RELAY IDENTIS.</u></p>
<p>Earth Stud</p>	



5

6

7

8

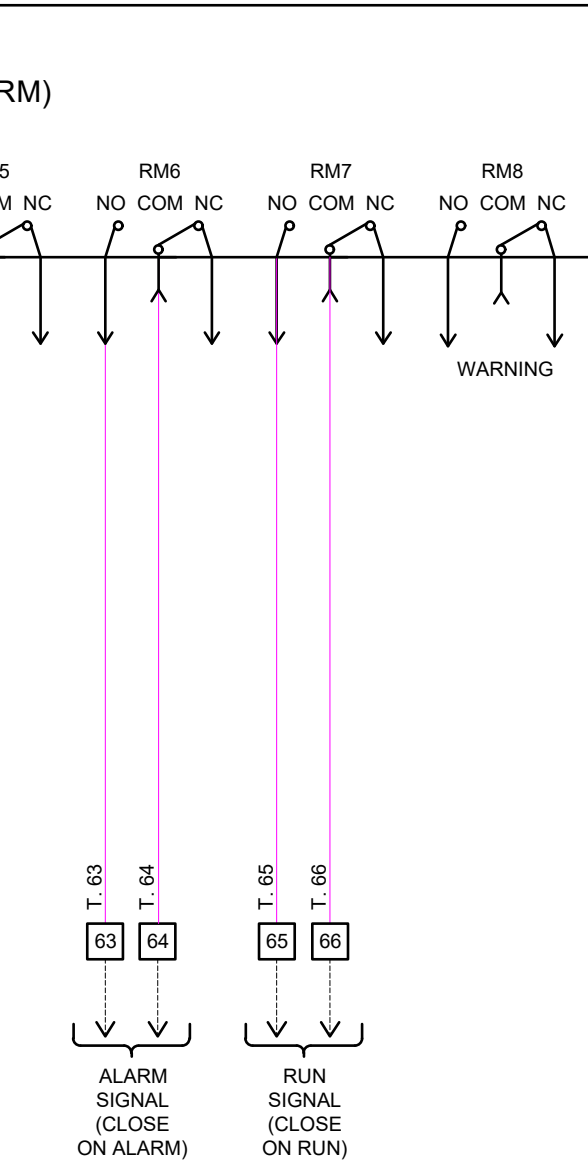

A1

Fens Pool Avenue  
 Brinerley Hill  
 West Midlands DY5 1QA  
 Tel: 01384 489 700  
 Fax: 01384 489 707

**ALWAYS MOVING FORWARD NEVER STANDING STILL.**

MODIFIED - QA9138	TITLE VAPAC VE T32 SINGLE PHASE WIRING SCHEMATIC VE05-1P / VE09-1P	DRAWN	LW	JOB No	
WIRING ADDED TO LIVE, NOW CONNECTED TO THERMAL - QA9088		DATE	17/11/23	DRAWING No. D301585	
WIRING THERMISTOR ADDED - QA9082	CLIENT	CHECKED	REVISION c		
WIRING RELEASE - QA9007	STANDARD	APPROVED	SHEET		3 of 3
DESCRIPTION					

# Appendix 2 - Wiring diagrams 3 phase single cylinder units

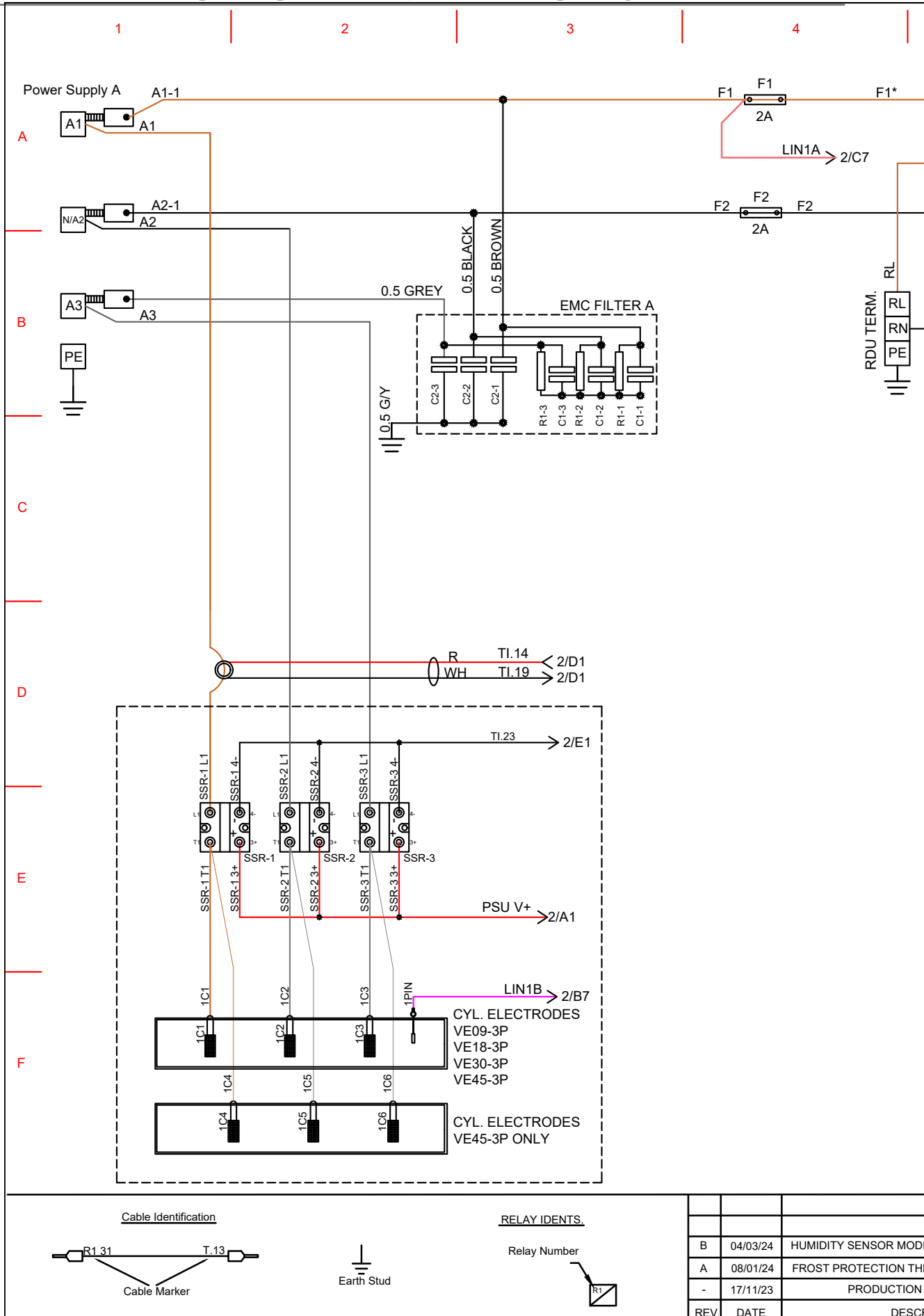

A2

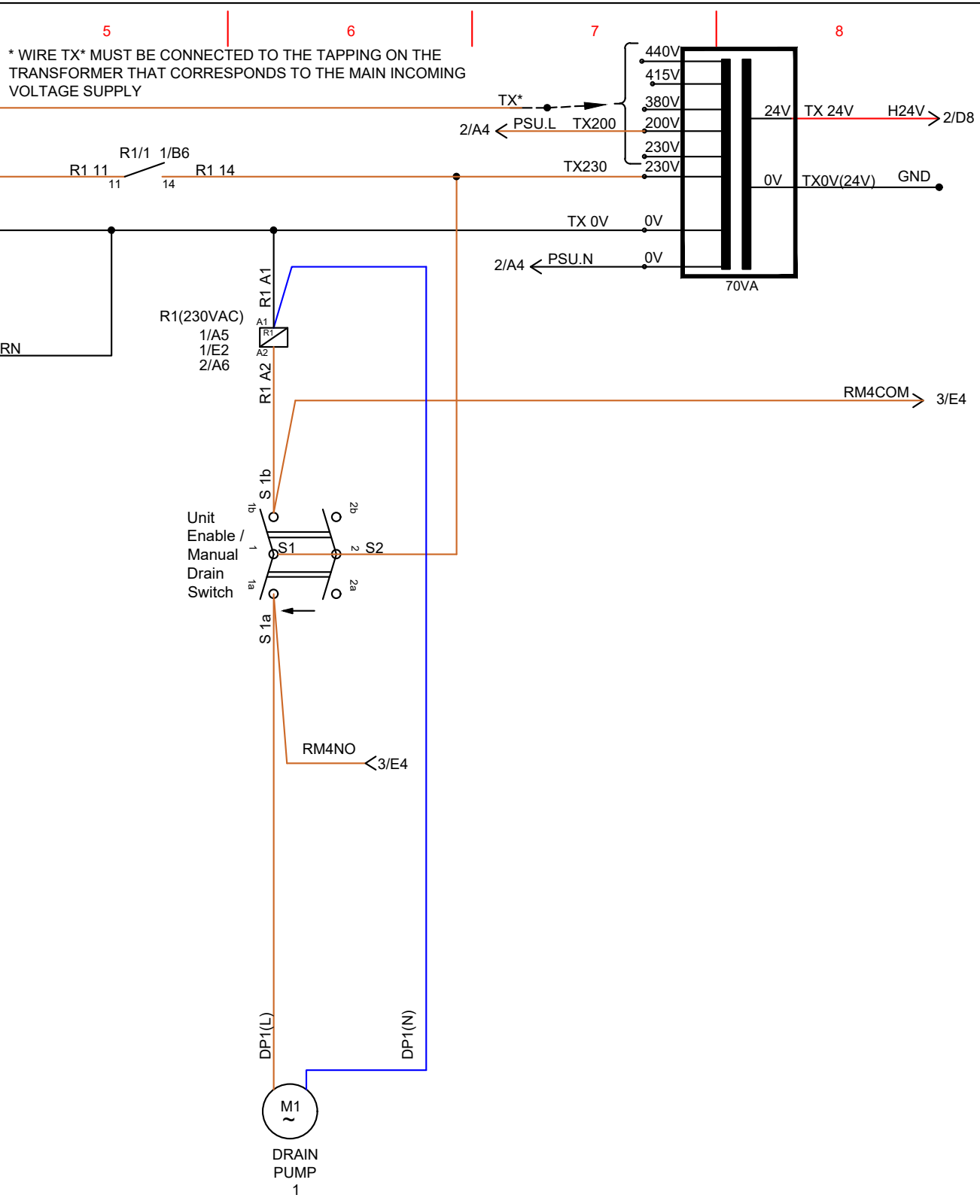

A2

Fens Pool Avenue  
 Brierley Hill  
 West Midlands DY5 1QA  
 Tel: 01384 489 700  
 Fax: 01384 489 707

ALWAYS MOVING FORWARD. NEVER STANDING STILL.

	TITLE VAPAC VE T32 THREE PHASE SINGLE CYLINDER WIRING SCHEMATIC VE09-3P / VE18-3P / VE30-3P / VE45-3P	DRAWN	LW	JOB No	
IFIED - QA9138		DATE	17/11/23	DRAWING No. D301586	
ERMISTOR ADDED - QA9082	CLIENT	CHECKED		REVISION	B
RELEASE - QA9007	STANDARD	APPROVED		SHEET	1 of 3
RIPTION					



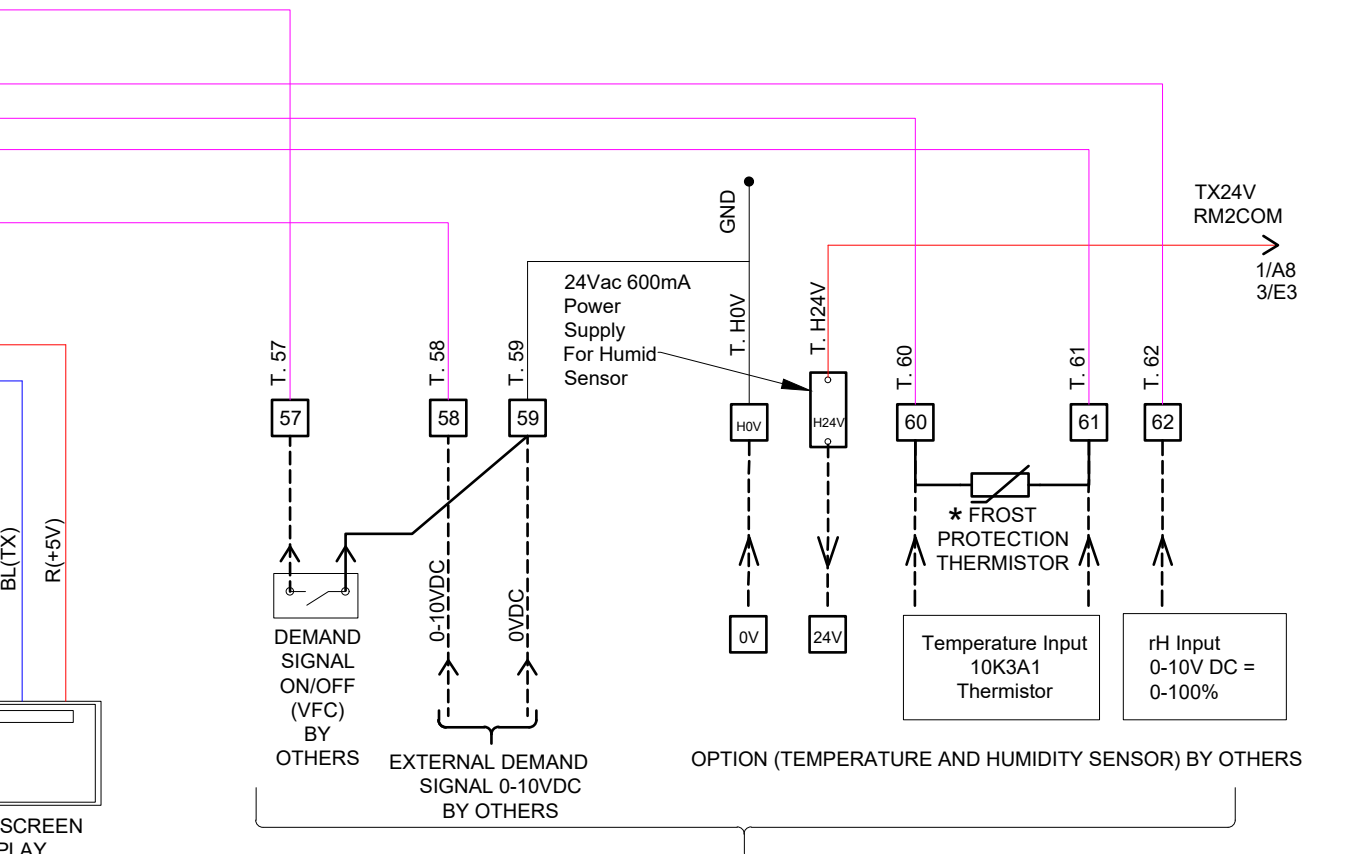
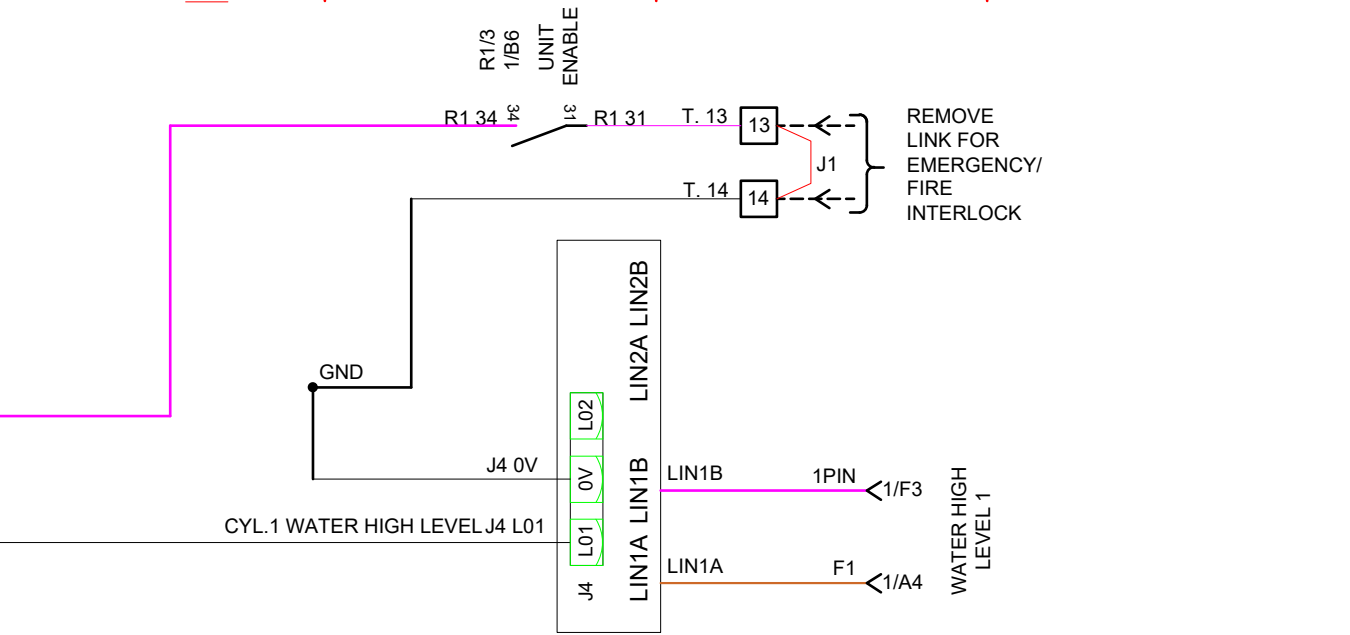

**NOTE: ONLY ONE INPUT TO BE ALLOWED FROM THE ABOVE.  
 FOR TEMPERATURE SENSORS WITH 0-24V OUTPUT USE TERMINALS T60 AND T61  
 FOR TEMPERATURE SENSORS WITH 0-10V OUTPUT USE TERMINALS T58 AND T59**

**FACTORY FITTED FROST PROTECTION THERMISTOR TO BE REMOVED  
 IF ALTERNATIVE INPUT IS FITTED**



TITLE	VAPAC VE T32 THREE PHASE SINGLE CYLINDER WIRING SCHEMATIC VE09-3P / VE18-3P / VE30-3P / VE45-3P	DRAWN	LW	ALWAYS MOVING FORWARD. NEVER STANDING STILL.	
DATE		DATE	17/11/23	JOB No	
CHEKED		CHEKED		DRAWING No. D301586	
APPROVED		APPROVED		REVISION B	SHEET 2 of 3



A2

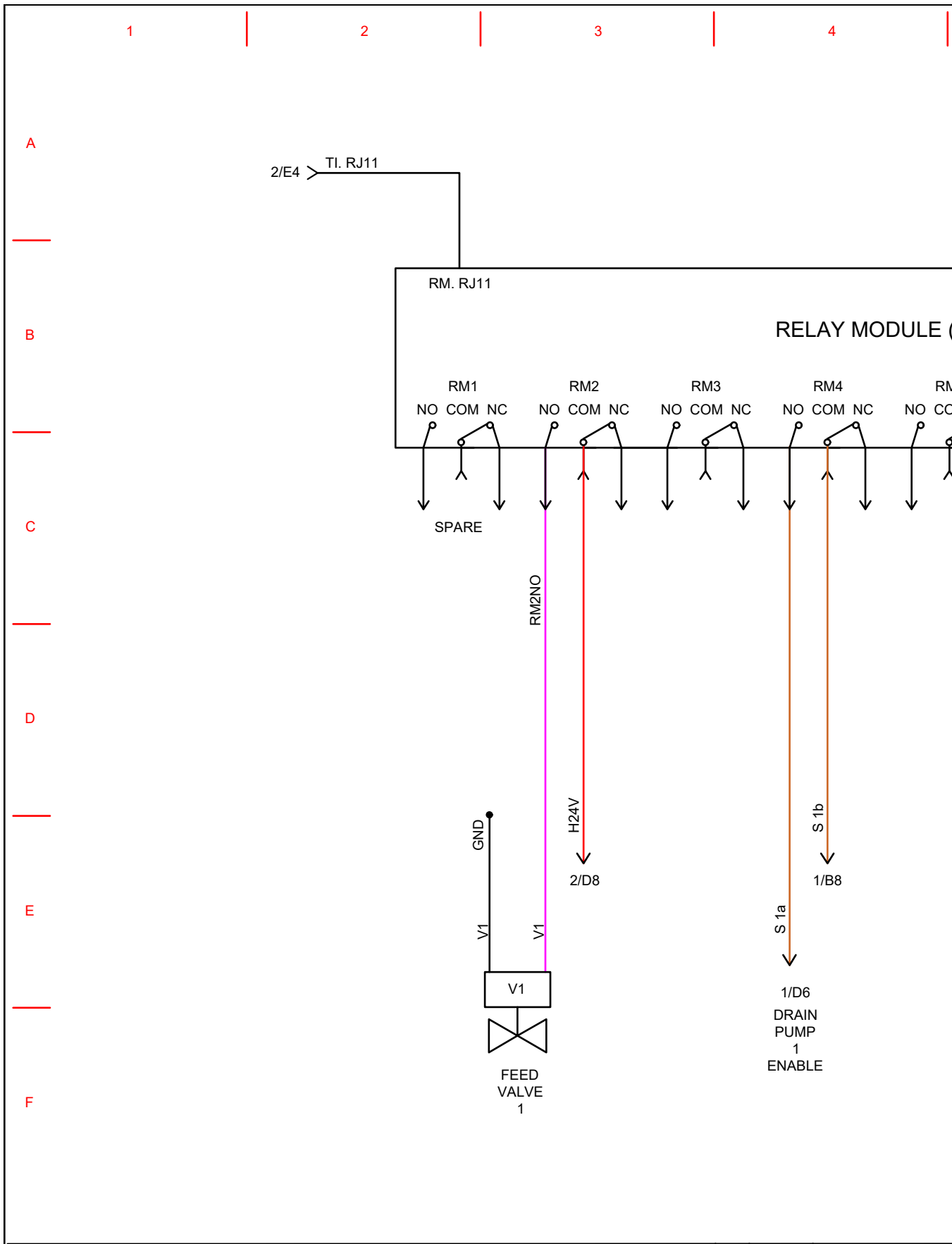

Cable Identification

RELAY IDENTS.

Relay Number

Earth Stud

B	04/03/24	HUMIDITY SENSOR MO
A	08/01/24	FROST PROTECTION T
-	17/11/23	PRODUCTION
REV	DATE	DES

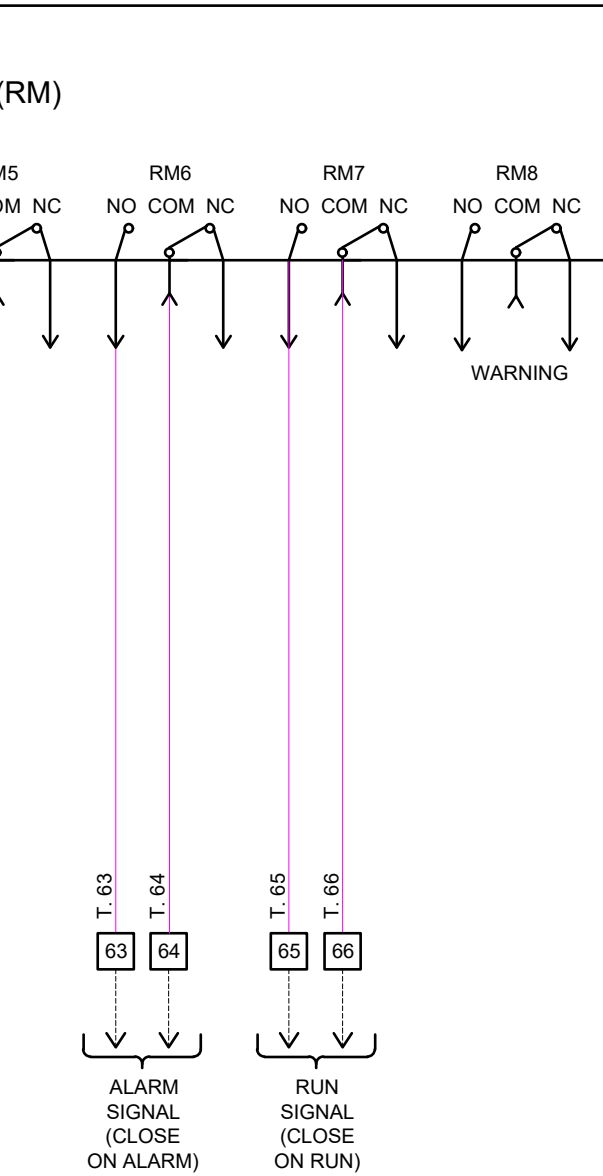

A2



DRAWN	LW	 ALWAYS MOVING FORWARD NEVER STANDING STILL		
	DATE			17/11/23
TITLE	VAPAC VE T32 THREE PHASE SINGLE CYLINDER WIRING SCHEMATIC VE09-3P / VE18-3P / VE30-3P / VE45-3P		DRAWING No.	D301586
CLIENT	STANDARD	CHECKED	APPROVED	REVISION B
DESCRIPTION				SHEET 3 of 3

# Appendix 3 - Wiring diagrams 3 phase double cylinder units

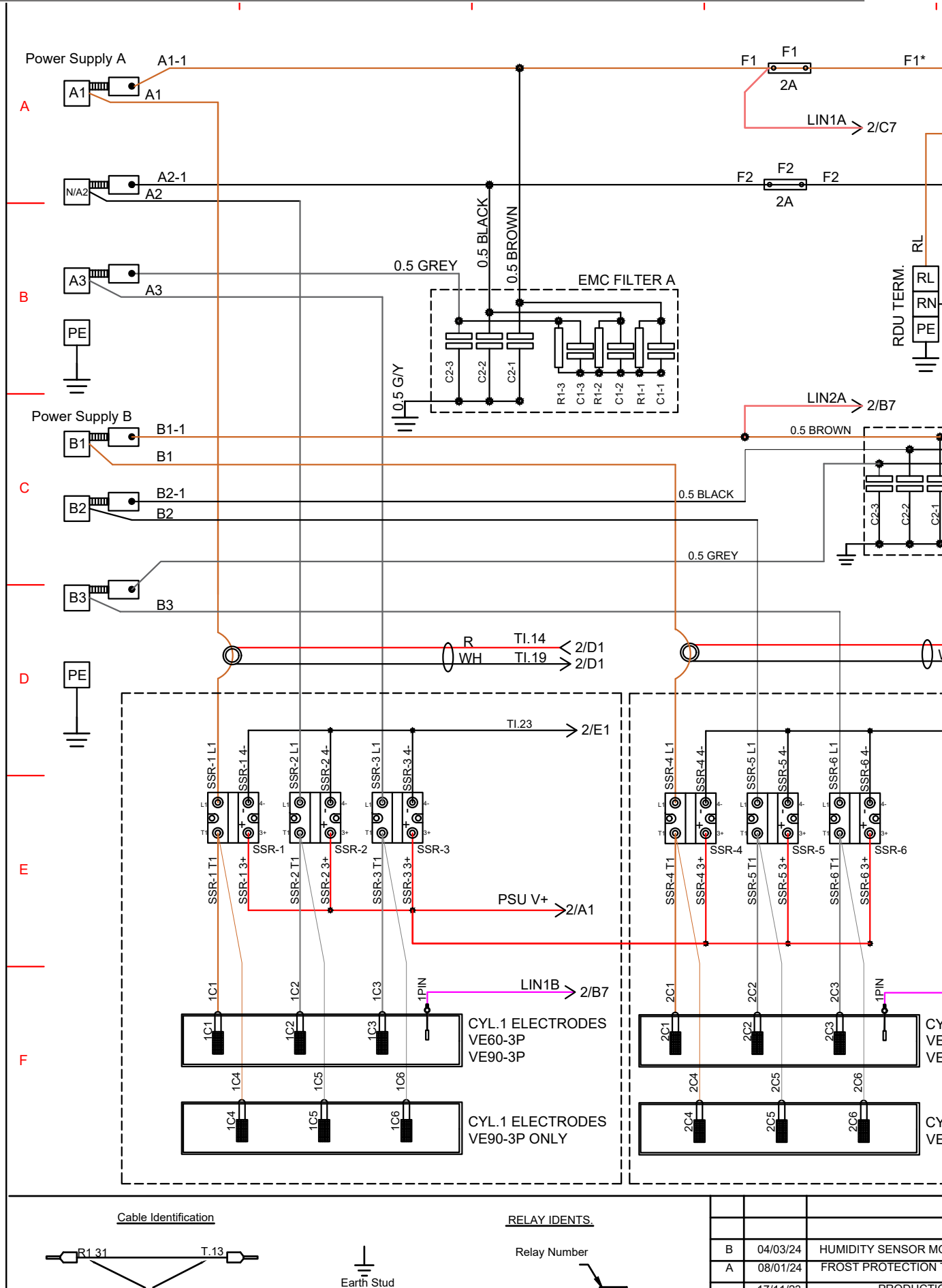

A3



\* WIRE TX\* MUST BE CONNECTED TO THE TAPPING ON THE TRANSFORMER THAT CORRESPONDS TO THE MAIN INCOMING VOLTAGE SUPPLY

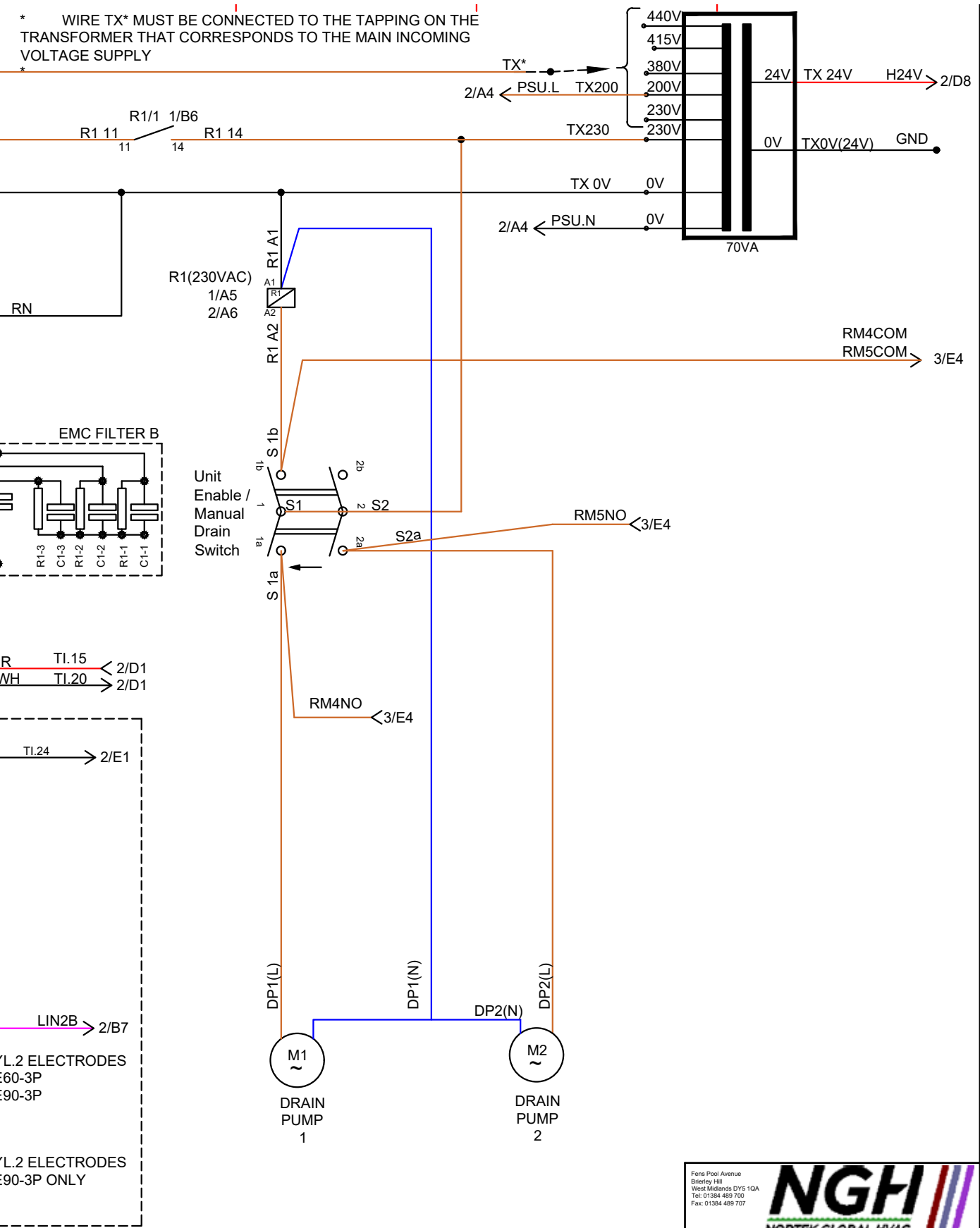

A3

MODIFIED - QA9138  
THERMISTOR ADDED - QA9082  
DATE RELEASED - QA9007

TITLE	VAPAC VE T32 THREE PHASE TWIN CYLINDER WIRING SCHEMATIC VE60-3P / VE90-3P	DRAWN	LW
DATE		17/11/23	JOB No
CHECKED			DRAWING No. D301587

Fens Pool Avenue  
Brierley Hill  
West Midlands DY5 1DA  
Tel: 01384 489 700  
Fax: 01384 489 707

**NGH**  
NORTEK GLOBAL HVAC

ALWAYS MOVING FORWARD NEVER STANDING STILL

A3

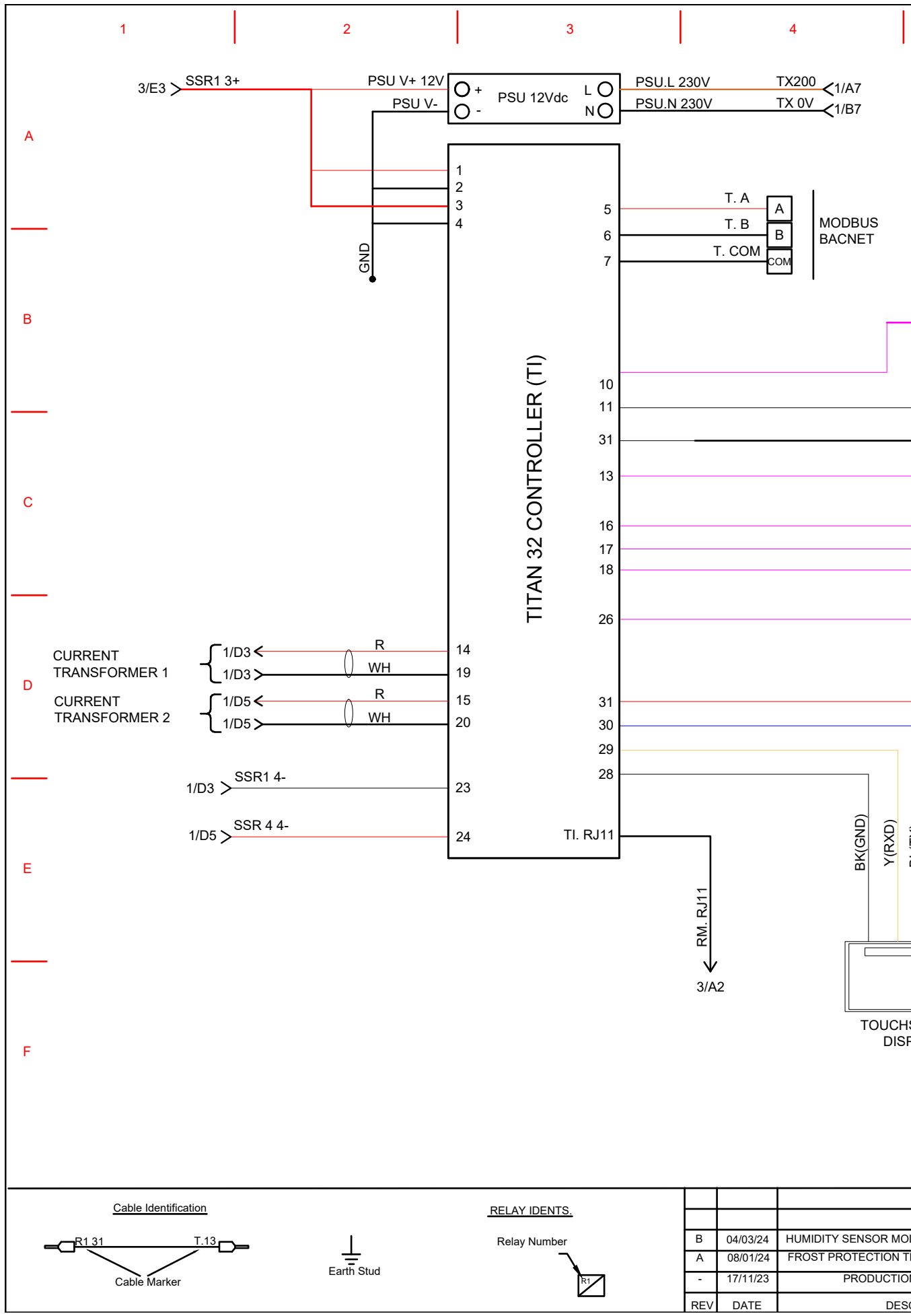

REV	DATE	DESC
B	04/03/24	HUMIDITY SENSOR MOI
A	08/01/24	FROST PROTECTION TI
-	17/11/23	PRODUCTION

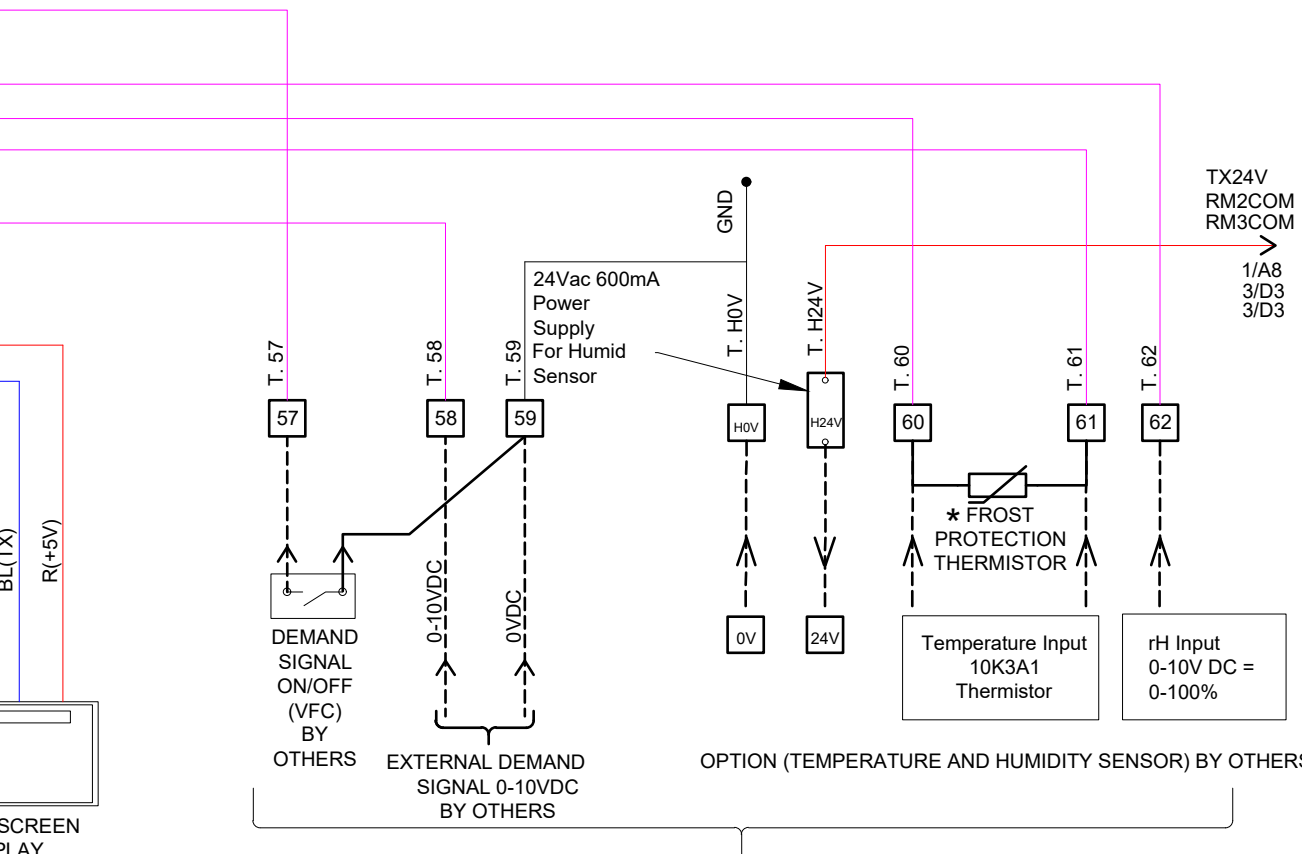
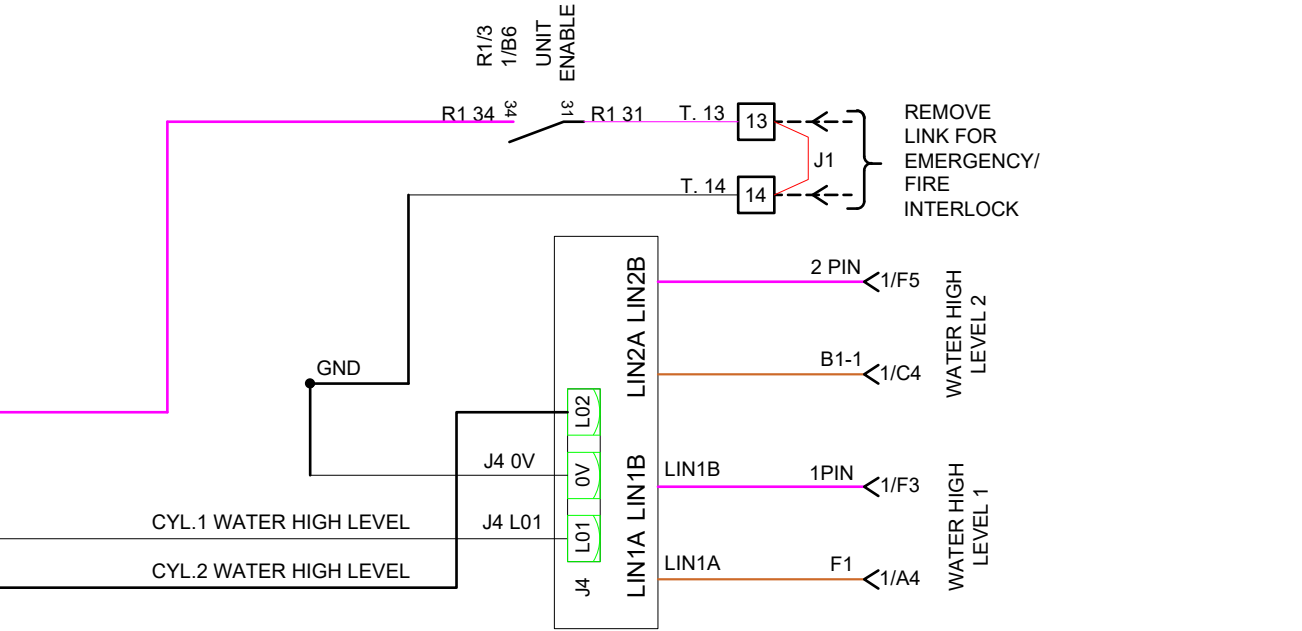

NOTE: ONLY ONE INPUT TO BE ALLOWED FROM THE ABOVE.  
 FOR TEMPERATURE SENSORS WITH 0-24V OUTPUT USE TERMINALS T60 AND T61  
 FOR TEMPERATURE SENSORS WITH 0-10V OUTPUT USE TERMINALS T58 AND T59

FACTORY FITTED FROST PROTECTION THERMISTOR TO BE REMOVED IF ALTERNATIVE INPUT IS FITTED

Ferns Pool Avenue  
 Brierley Hill  
 West Midlands DY5 1QA  
 Tel: 01384 489 700  
 Fax: 01384 489 707

ALWAYS MOVING FORWARD. NEVER STANDING STILL.

TITLE	VAPAC VE T32 THREE PHASE TWIN CYLINDER WIRING SCHEMATIC VE60-3P / VE90-3P	DRAWN	LW	ALWAYS MOVING FORWARD. NEVER STANDING STILL.	
DATE	17/11/23	CHECKED		JOB No	
CLIENT		APPROVED		DRAWING No. D301587	
STANDARD				REVISION	B SHEET 2 of 3



A3

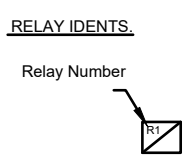
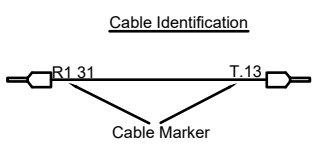
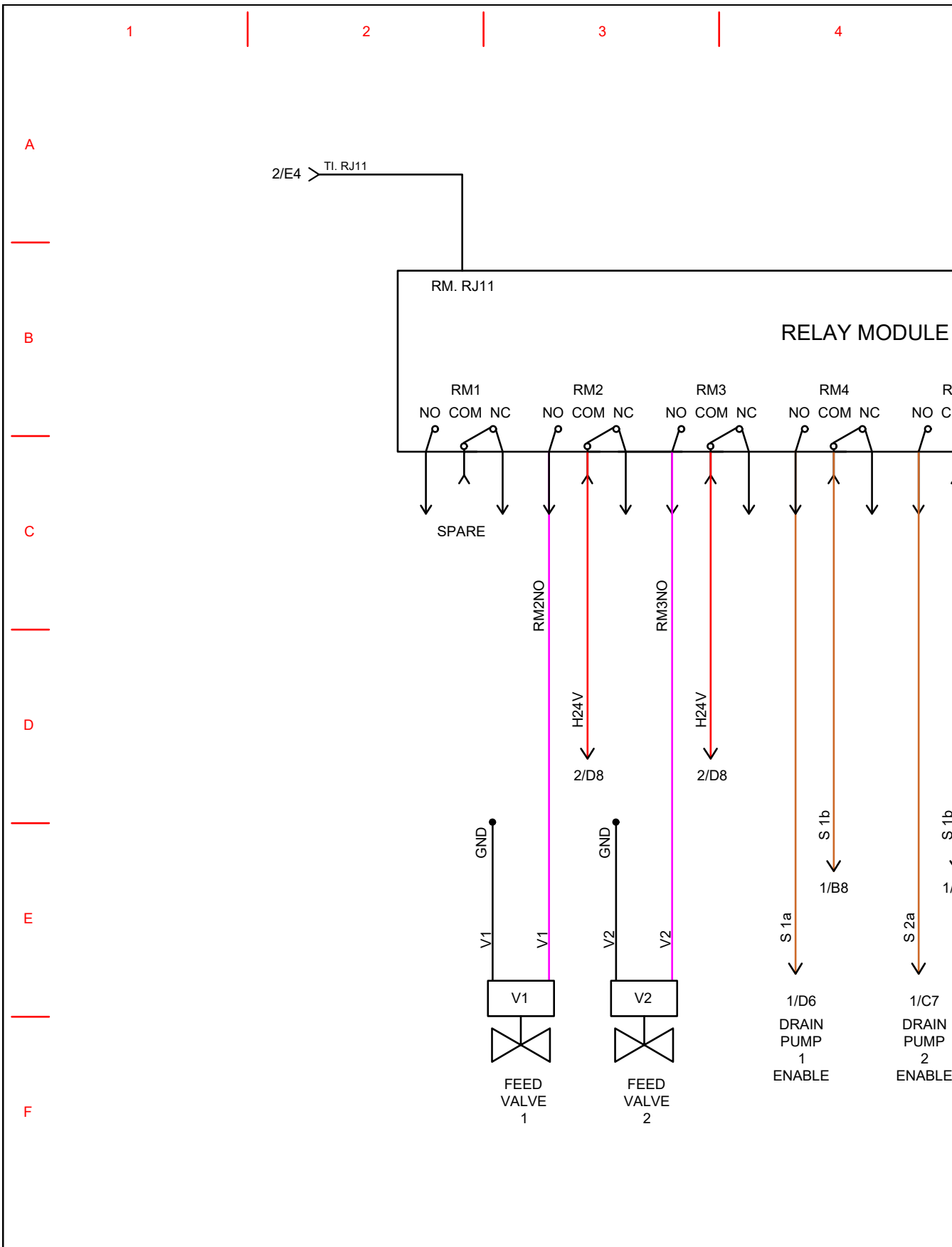

B	04/03/24	HUMIDITY SENSOR M
A	08/01/24	FROST PROTECTION
-	17/11/23	PRODUCTI
REV	DATE	DES

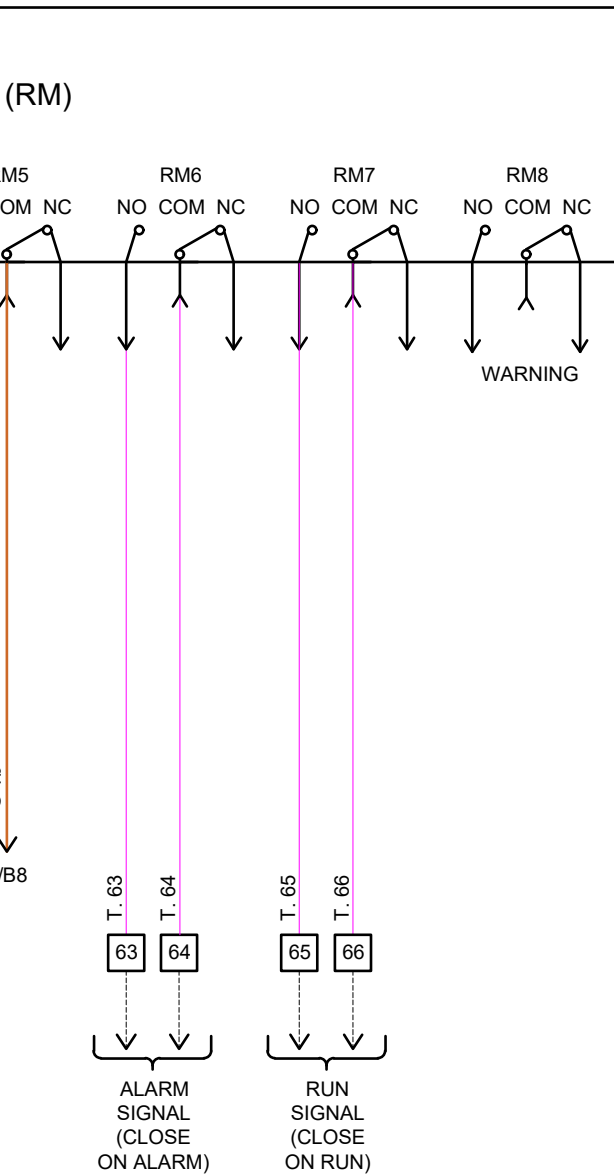

A3

Fens Pool Avenue  
Brierley Hill  
West Midlands DY5 1QA  
Tel: 01384 489 700  
Fax: 01384 489 707

**ALWAYS MOVING FORWARD. NEVER STANDING STILL.**

MODIFIED - QA9138	TITLE VAPAC VE T32 THREE PHASE TWIN CYLINDER WIRING SCHEMATIC VE60-3P / VE90-3P	DRAWN	LW	JOB No
WIRING THERMISTOR ADDED - QA9082		DATE	17/11/23	
ON RELEASE - QA9007	CLIENT	CHECKED		DRAWING No. D301587
DESCRIPTION	STANDARD	APPROVED		REVISION B SHEET 3 of 3

# Notes

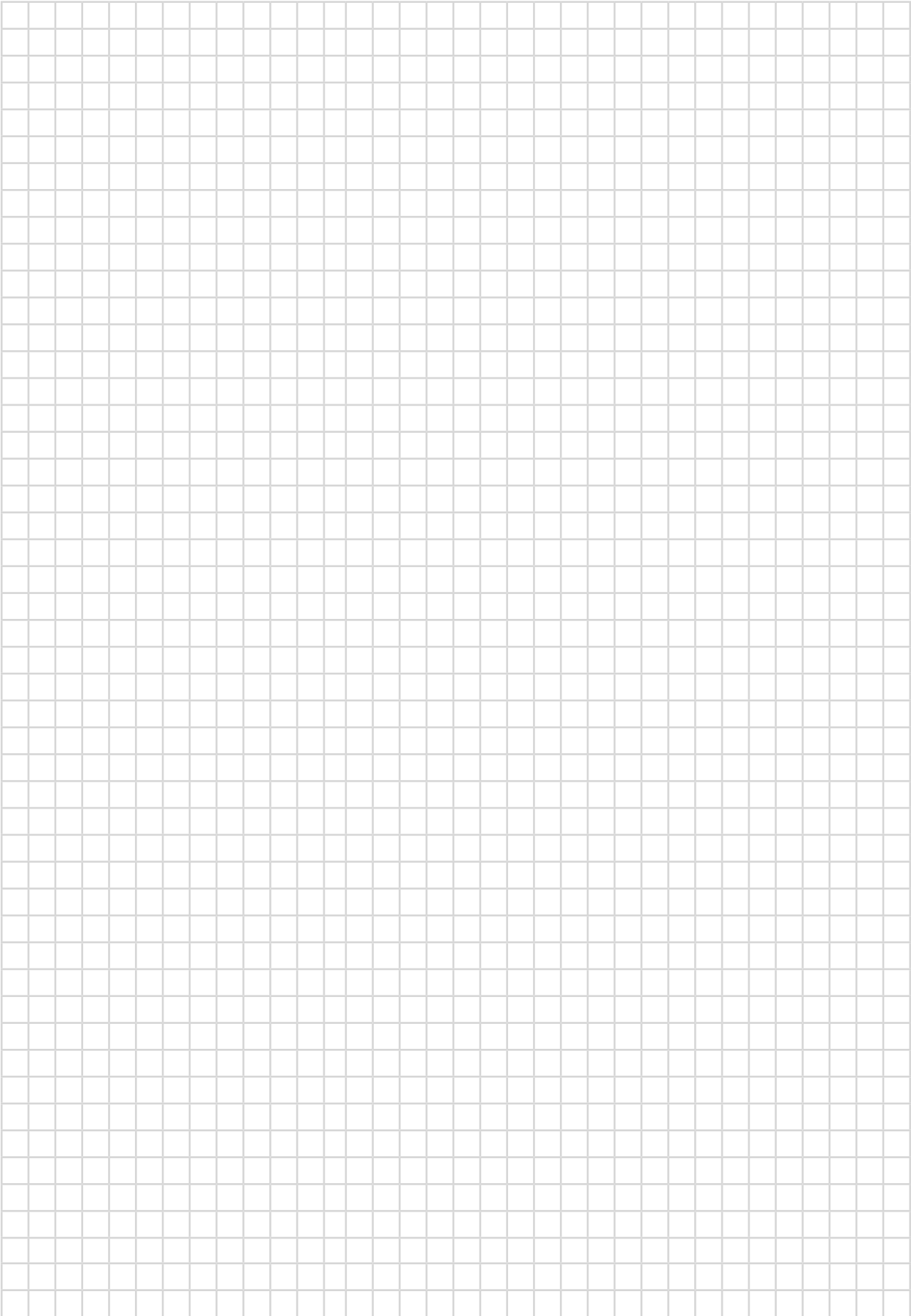

# Notes

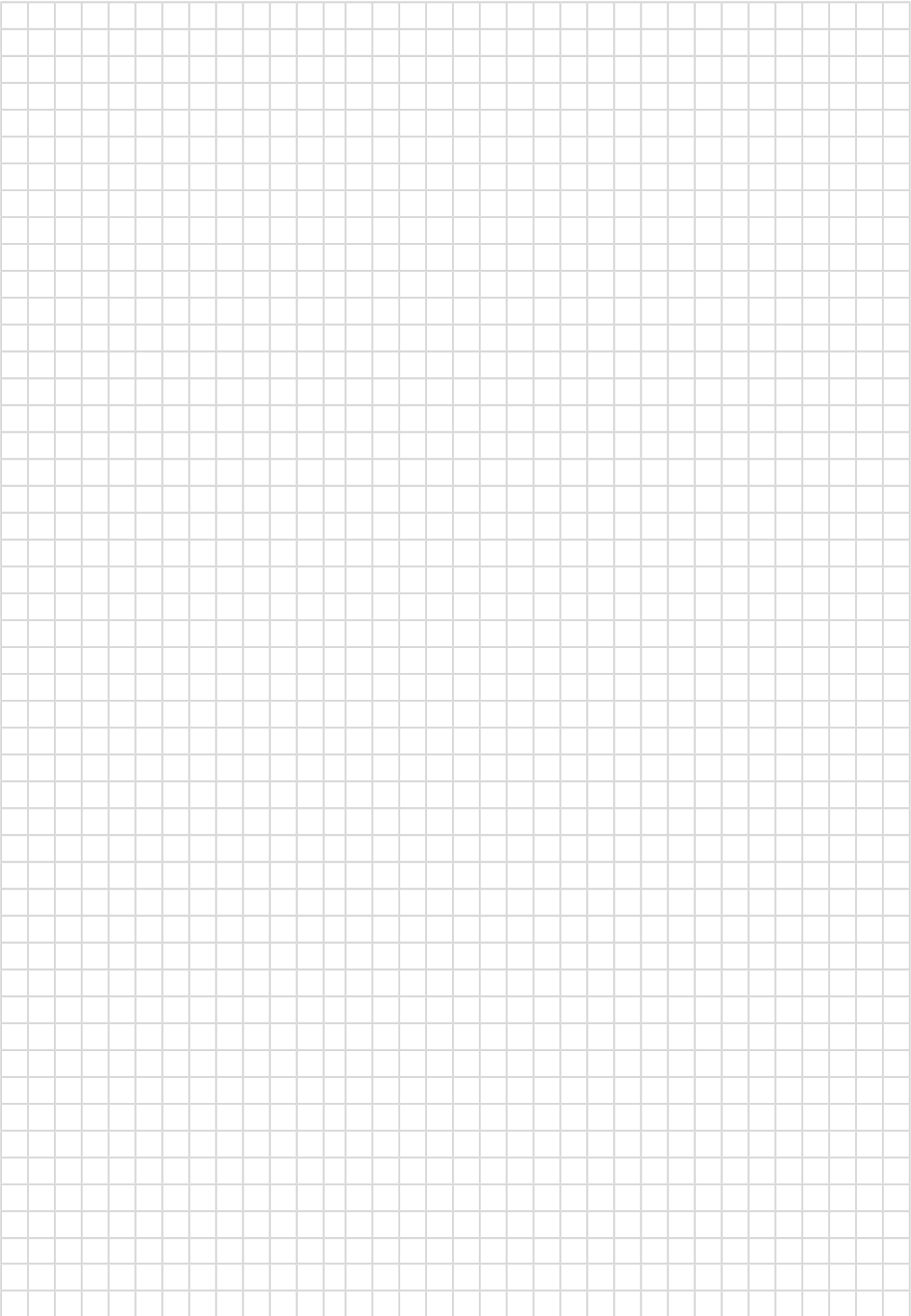



**NORTEK GLOBAL HVAC (UK) LTD**

Fens Pool Avenue  
Brierley Hill  
West Midlands  
DY5 1QA  
United Kingdom  
Tel +44 (0)1384 489700  
Fax +44 (0)1384 489707  
vapacsales@nortek.com  
www.vapac.com

Nortek Global HVAC is a registered trademark of Nortek Global HVAC limited. Because of the continuous product innovation, Nortek Global HVAC reserves the right to change product specification without due notice.