

# DATASHEET

## THE MOBILE RANGE - SMALL, LIGHT AND ROBUST

Lift it, push it, turn it or swing it around, this selection of compact, lightweight dehumidifiers is built for mobility.

### TECHNICAL DATA

#### CR80B

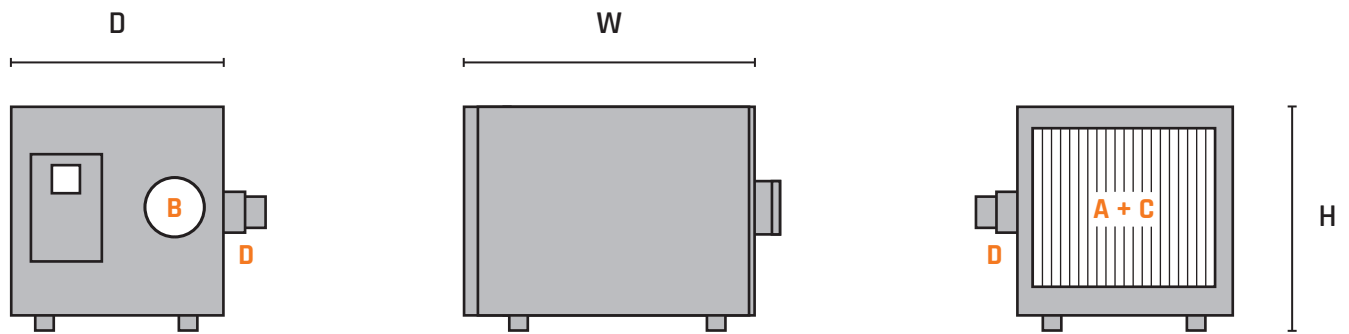

#### CR240B / CR290B

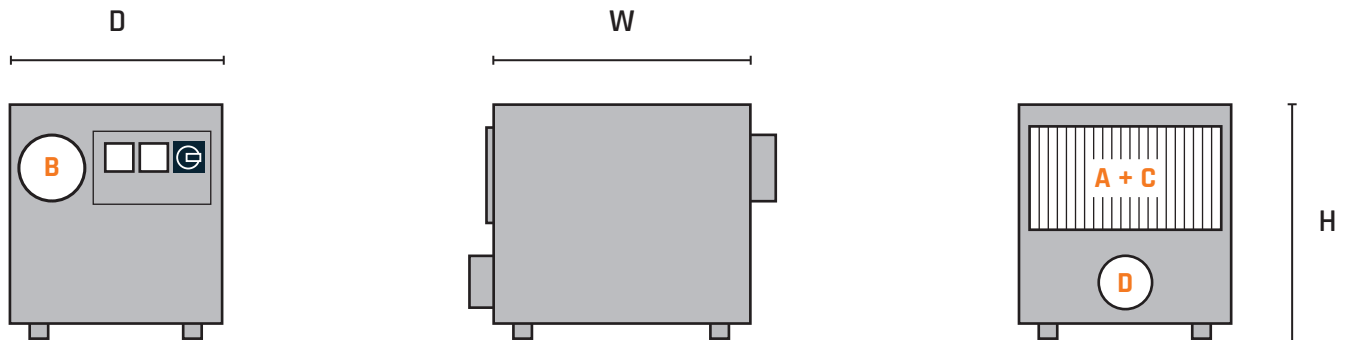

#### CR400B

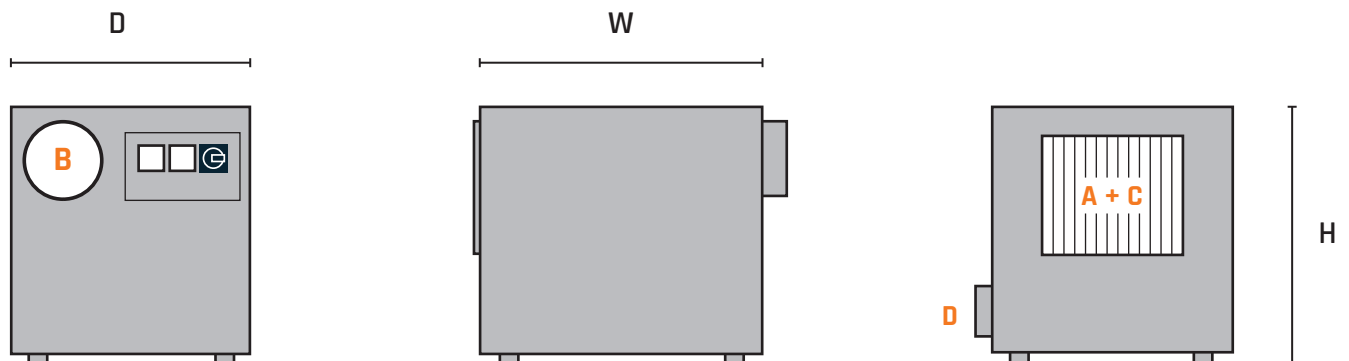

## THE MOBILE RANGE

# TECHNICAL DATA

Performance data is based on nominal conditions 20°C, 60%RH.

THE MOBILE RANGE					
		CR80B	CR240B	CR290B	CR400B
<b>TECHNICAL DATA</b>					
DRY AIR	m³/h	80	240	290	400
REGENERATION AIR	m³/h	40	40	65	90
VOLTAGE/PHASES	V/PH	1 x 230V PH+N+PE	1 x 230V PH+N+PE	1 x 230V PH+N+PE	1 x 230V PH+N+PE
CONNECTED LOAD	kW	0.83	1.05	1.63	1.97
REGENERATION AIR HEATER	kW	0.77	0.94	1.4	1.84
MAXIMUM FUSE SIZE	A	10	10	10	10
EXT. PRESSURE PROCESS AIR	Pa	50	50	30	50
EXT. PRESSURE REGENERATION AIR	Pa	60	50	50	50
MOISTURE REMOVAL CAPACITY	kg/h	0.44	0.8	1.1	1.4
<b>DIMENSIONS AND WEIGHT</b>					
W WIDTH	mm	385	400	400	472
D DEPTH	mm	313	333	333	407
H HEIGHT	mm	293	363	363	405
WEIGHT	kg	15	18	19	28
<b>DUCT CONNECTIONS</b>					
A PROCESS AIR INLET	mm	231 x 257	270 x 140	270 x 140	210 x 350
B PROCESS AIR OUTLET	mm	Ø80	Ø100	Ø100	Ø125
C REGENERATION AIR INLET	mm	231 x 257	270 x 140	270 x 140	210 x 350
D REGENERATION AIR OUTLET	mm	Ø50	Ø80	Ø80	Ø80